

I n s t r u k c j a M o n t a ż u

BTR  **SYSTEMS**
The Best Type of Roofing

GRUPA  **BLACHOTRAPEZ**

 **THUNDER**
STONE ROOFING REVOLUTION

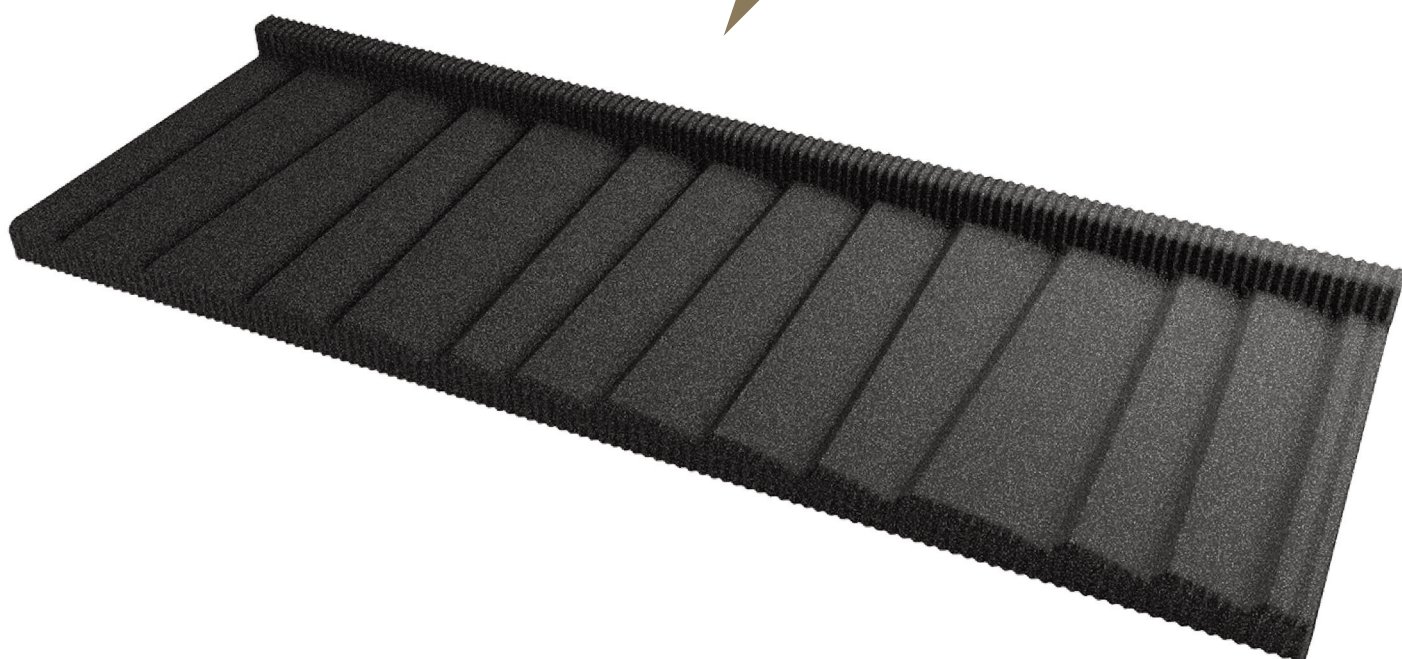

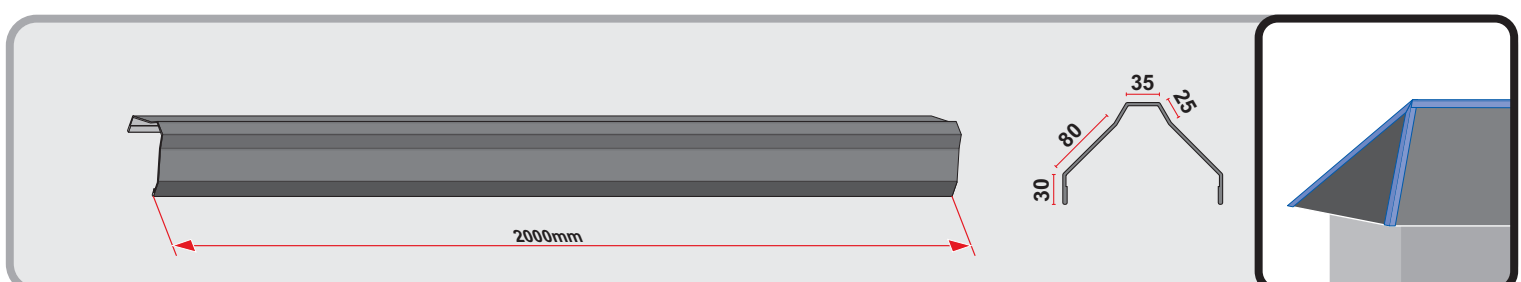
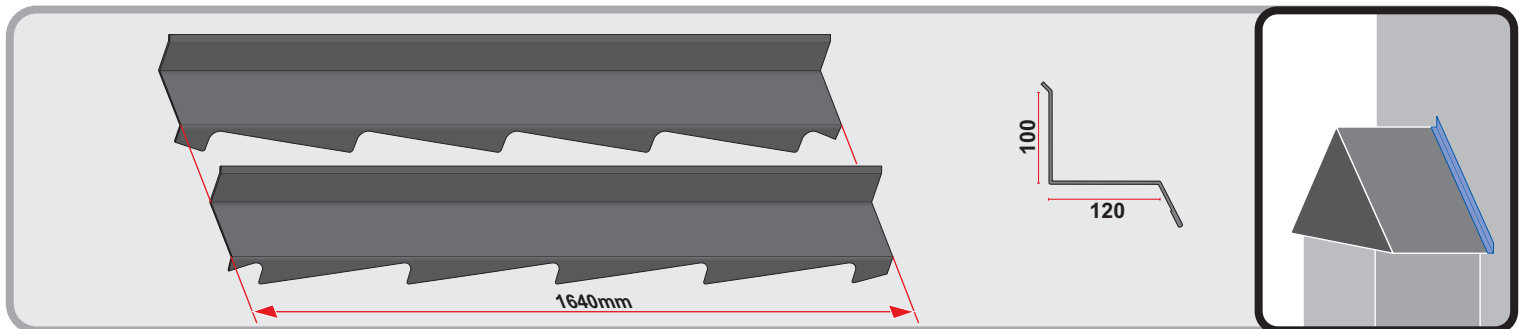
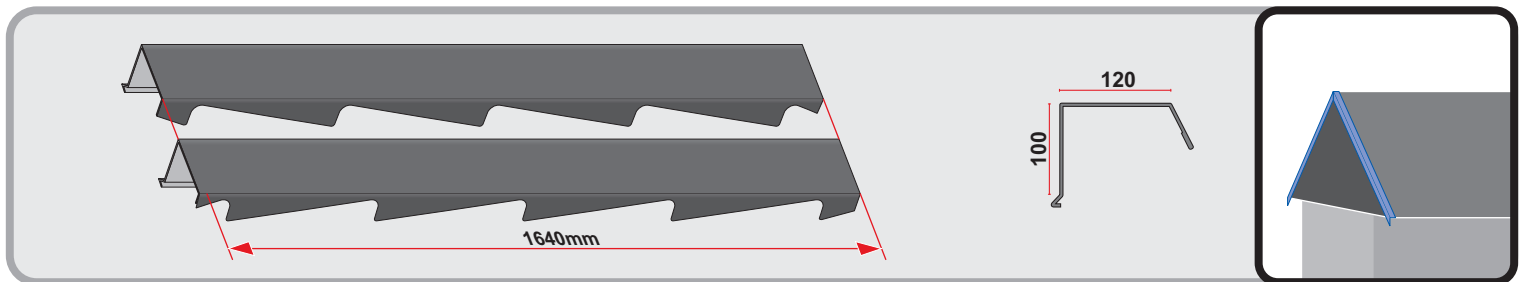
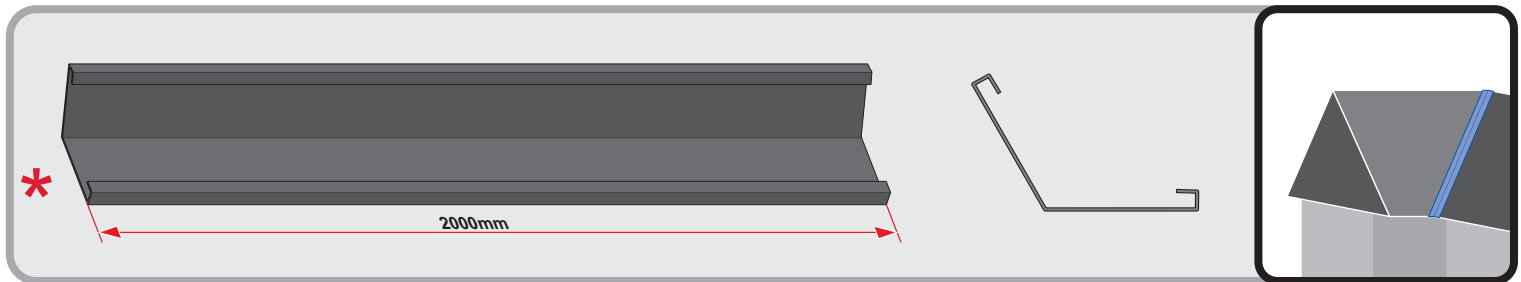
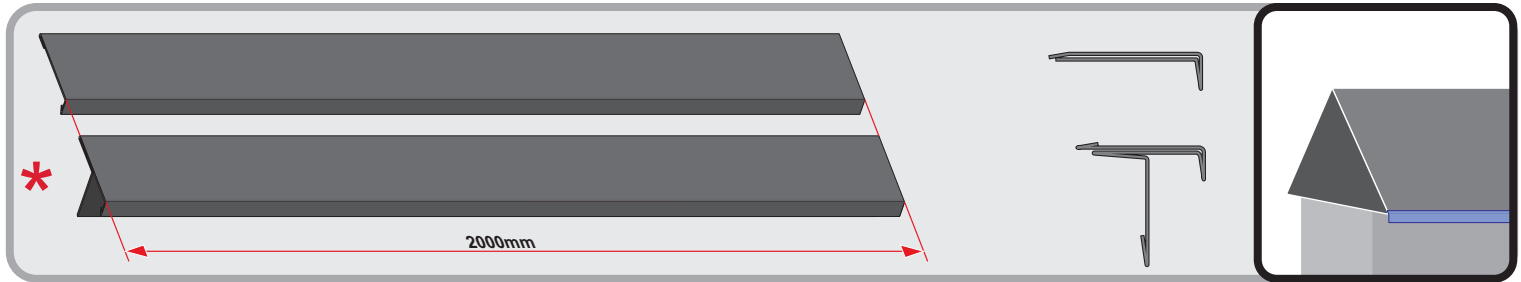
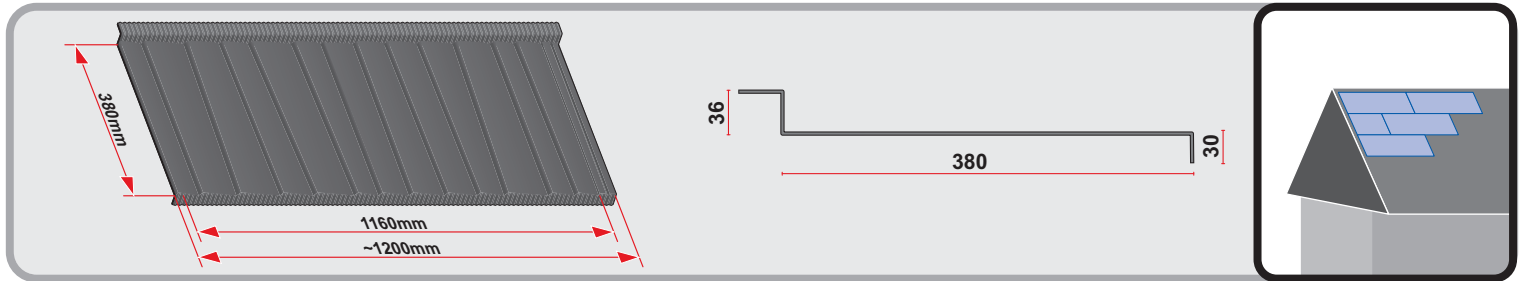

✱ Obróbki z gwiazdką wykonane na zamówienie z blachy Pladur® Relief Textured Wood.

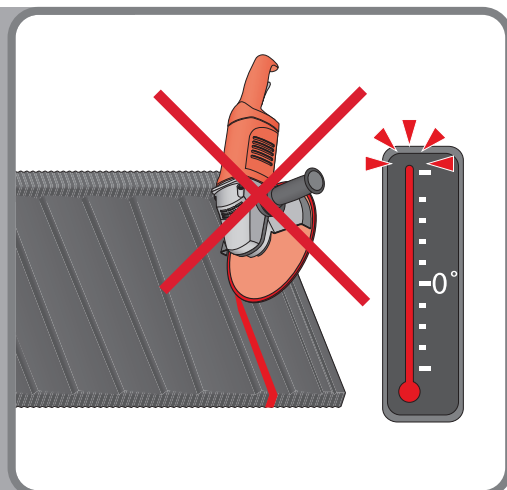
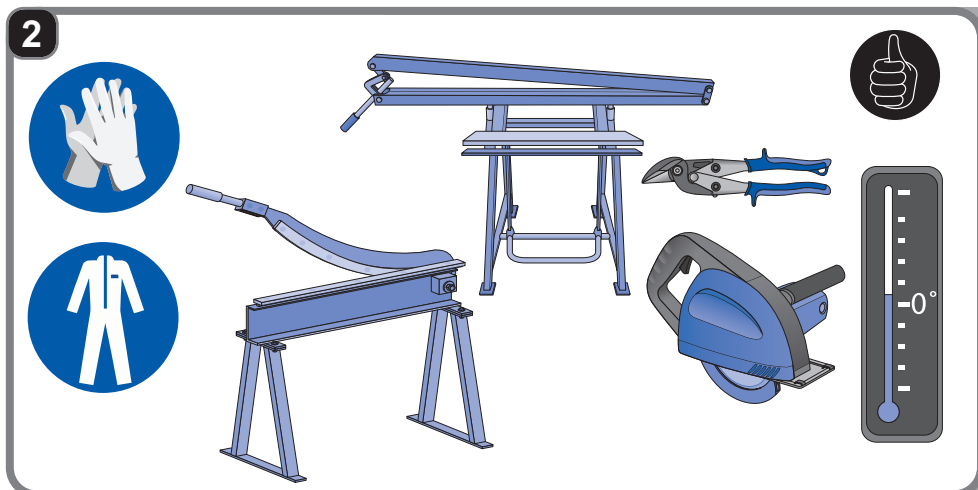
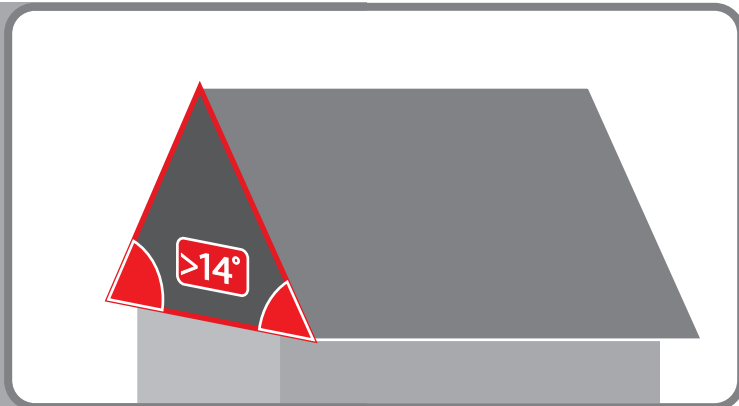
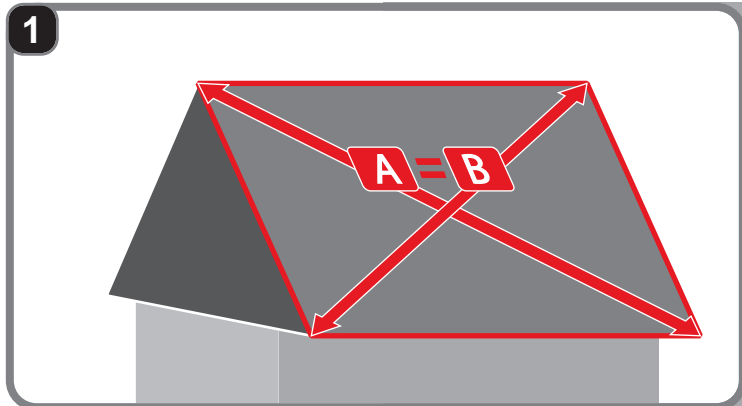

Nie zaleca się montażu w temperaturze poniżej 5°C. Nie należy montować, wyginać ani chodzić po arkuszach, gdy są zawilgocone.

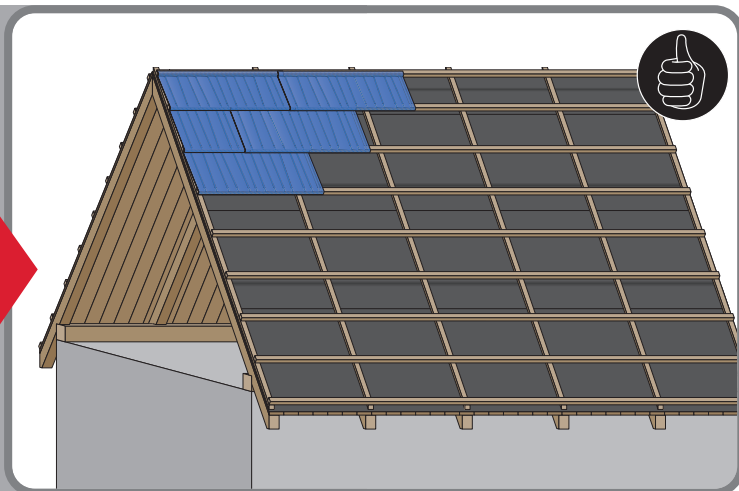
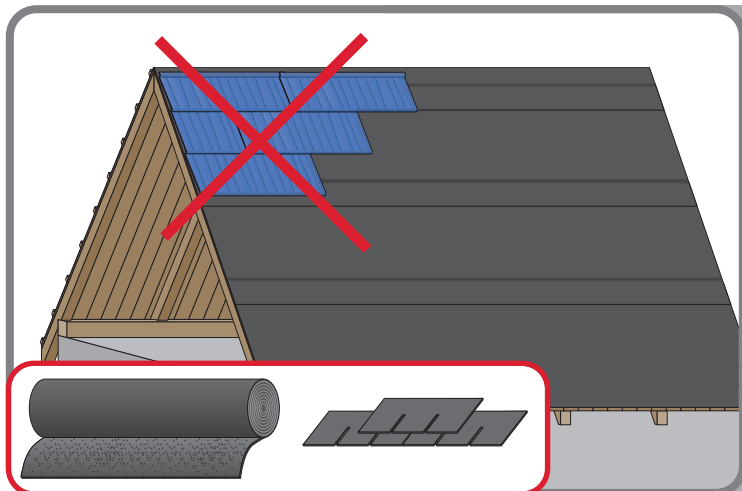
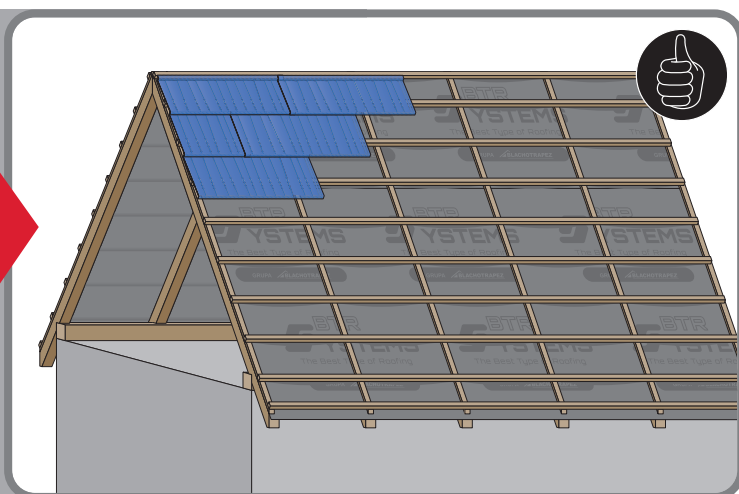
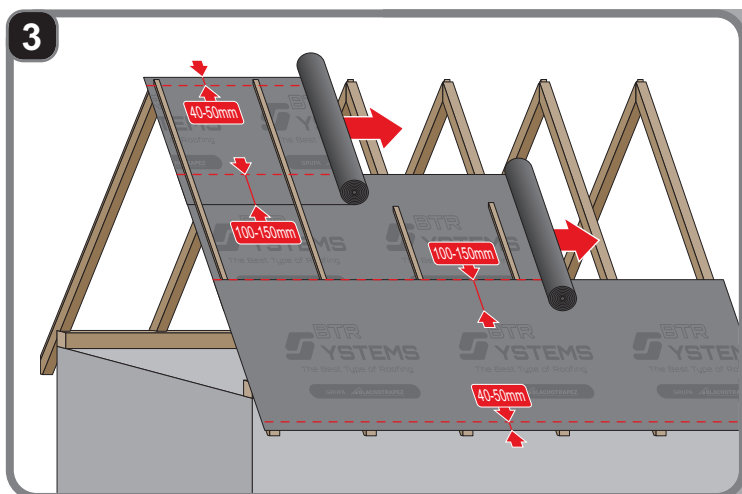

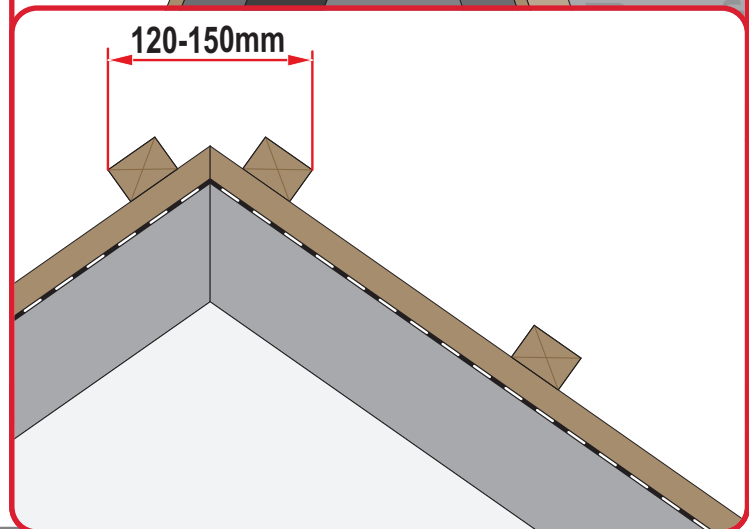
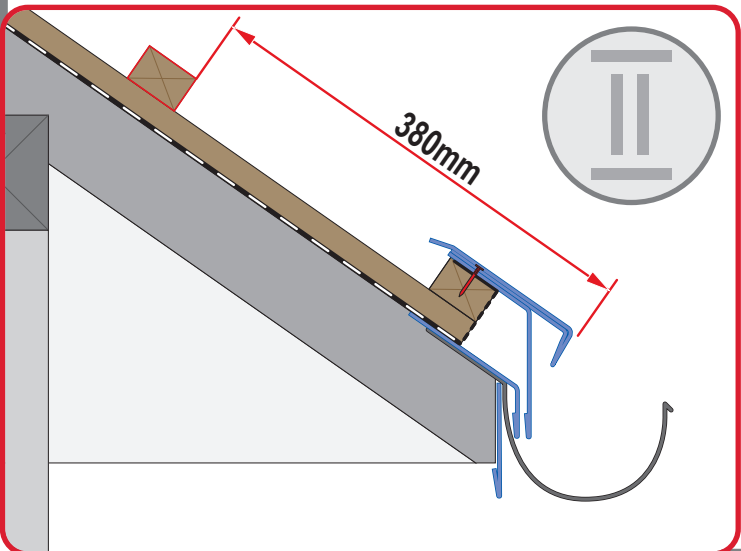
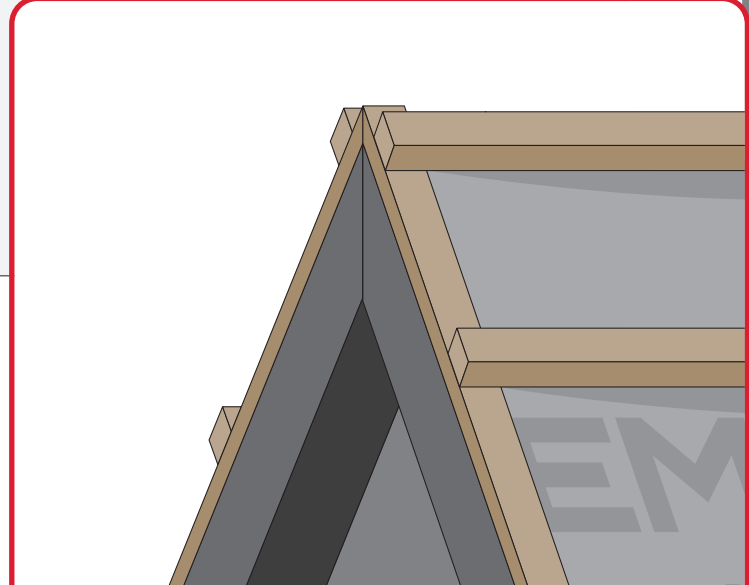
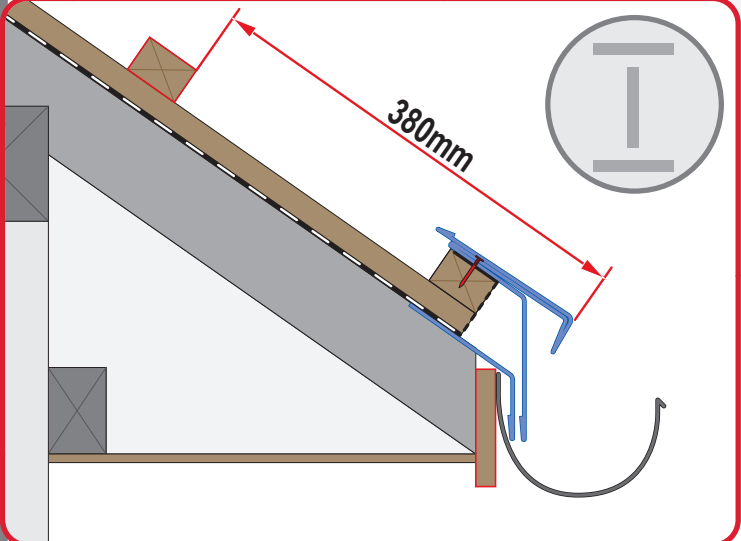
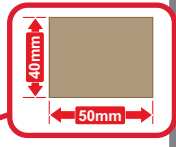
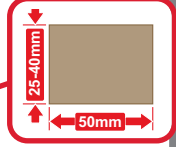
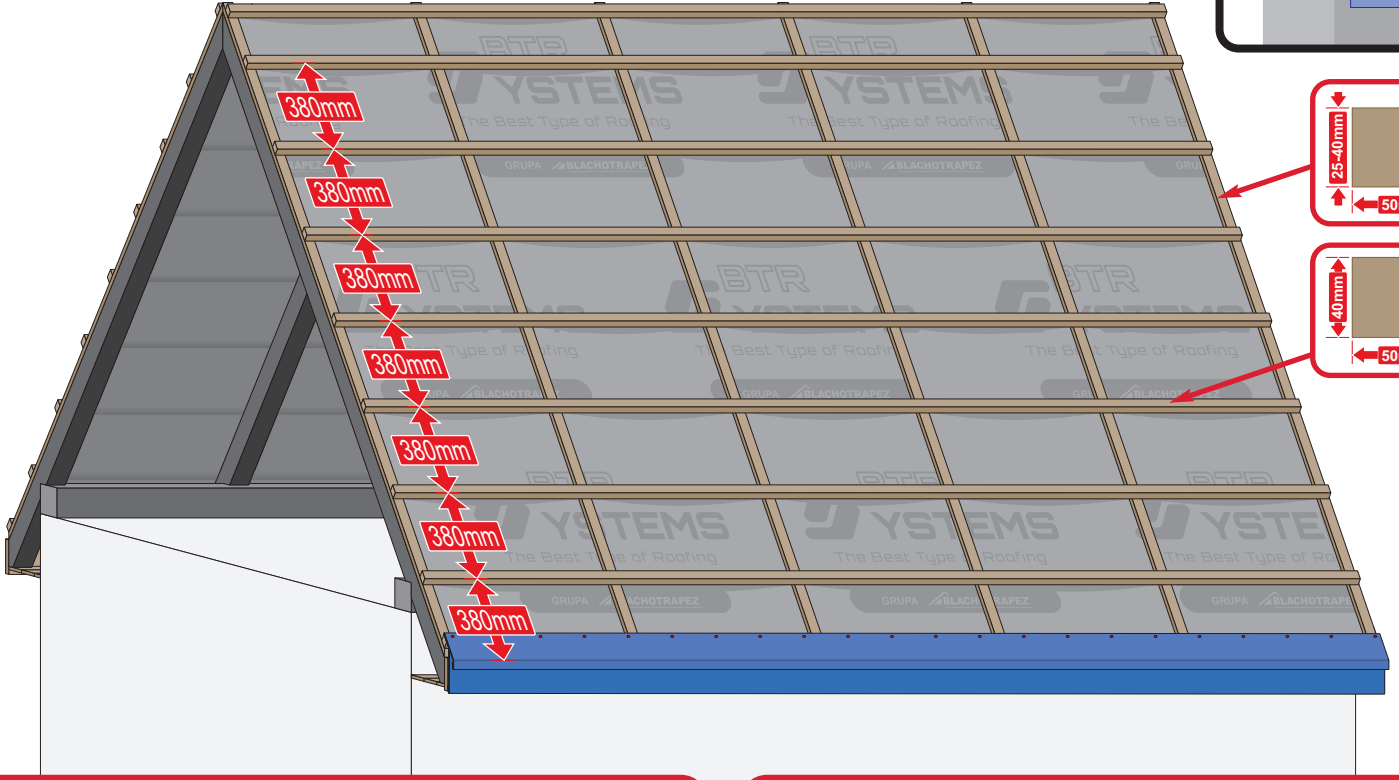
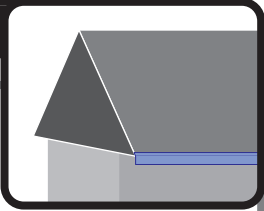

5a

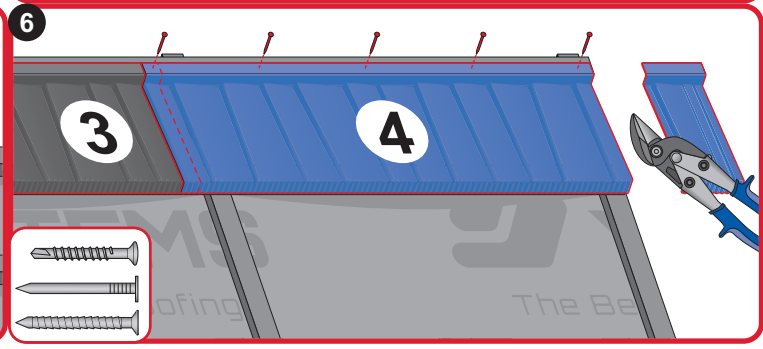
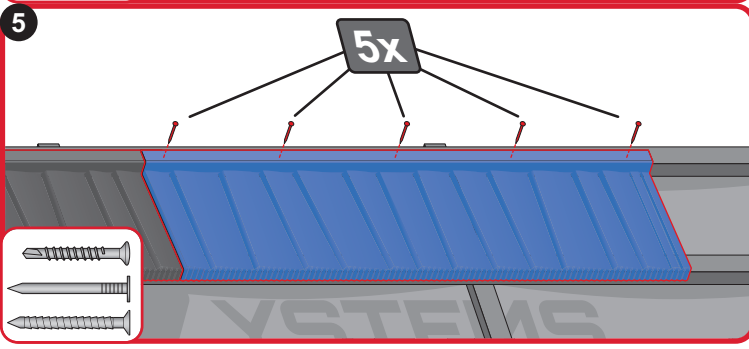
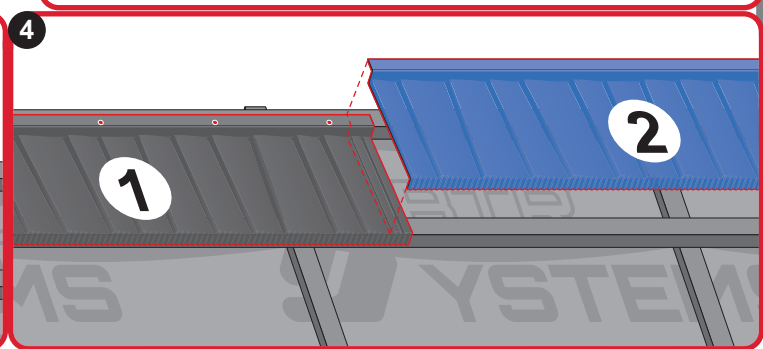
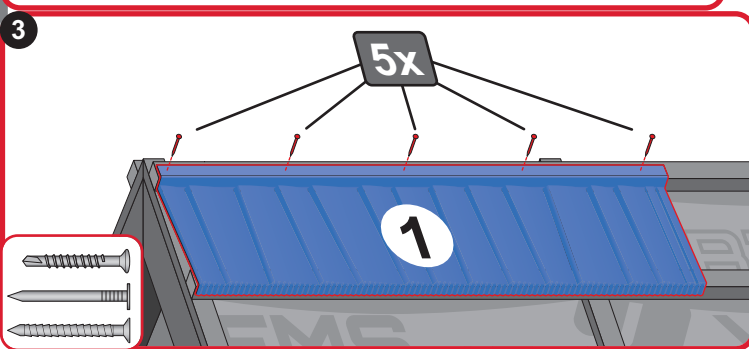
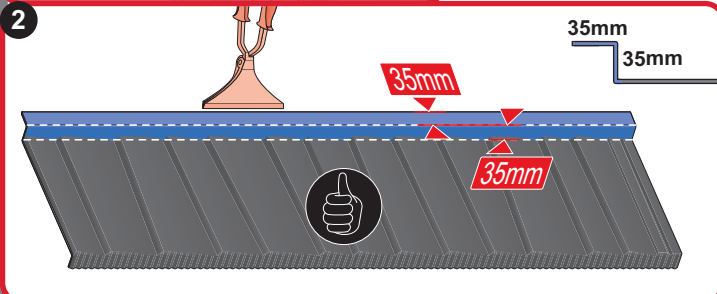
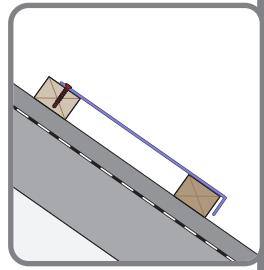
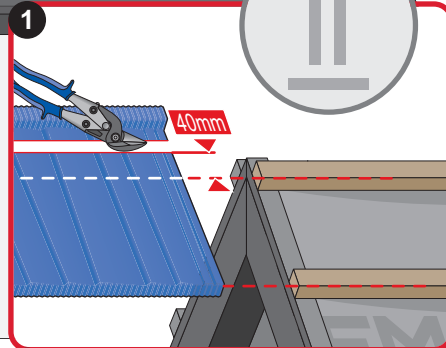
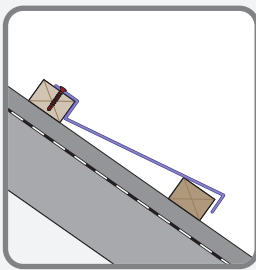
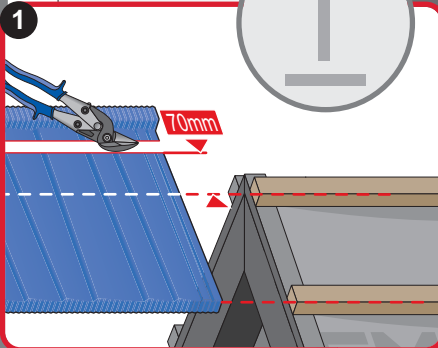
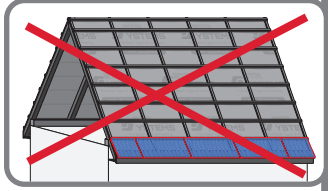
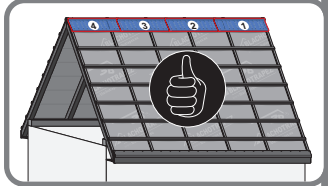
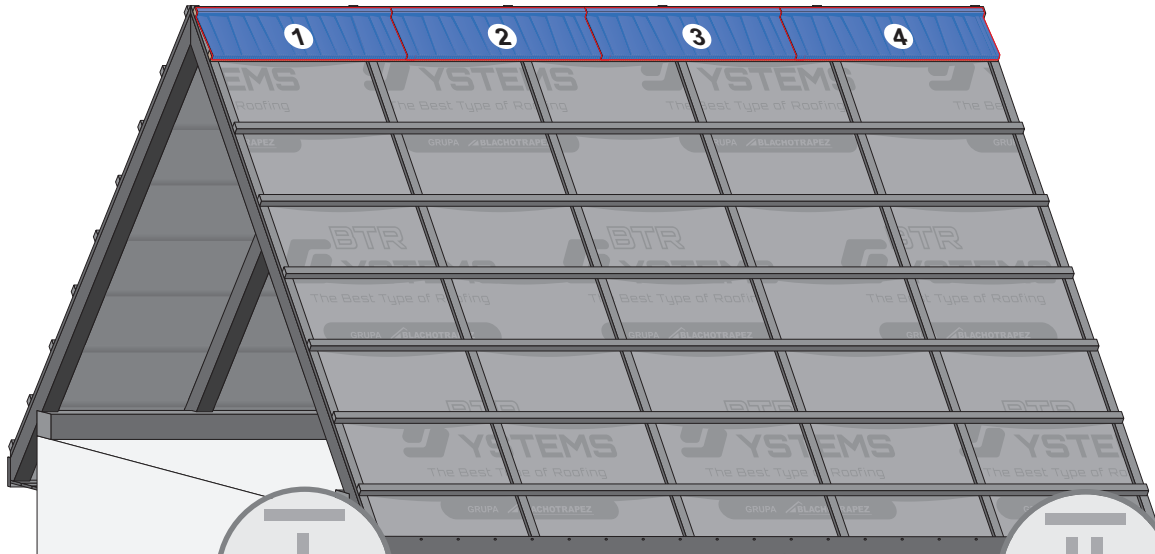
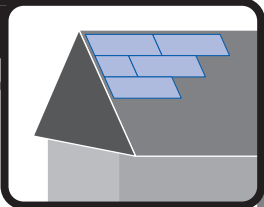

5b

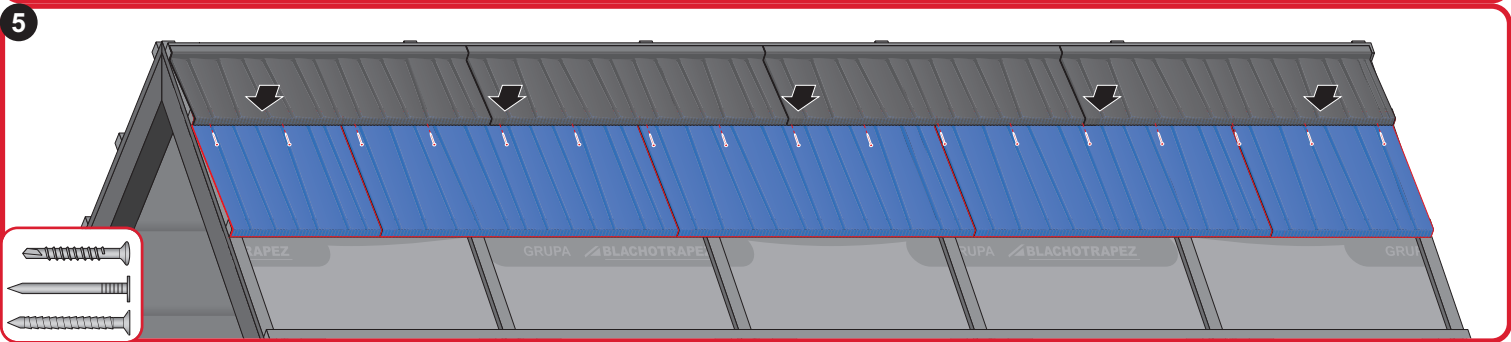
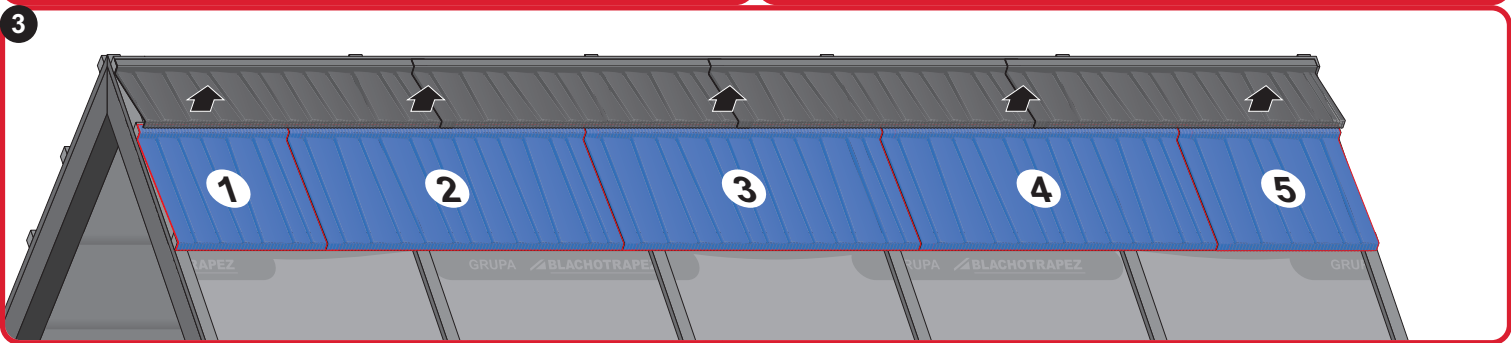
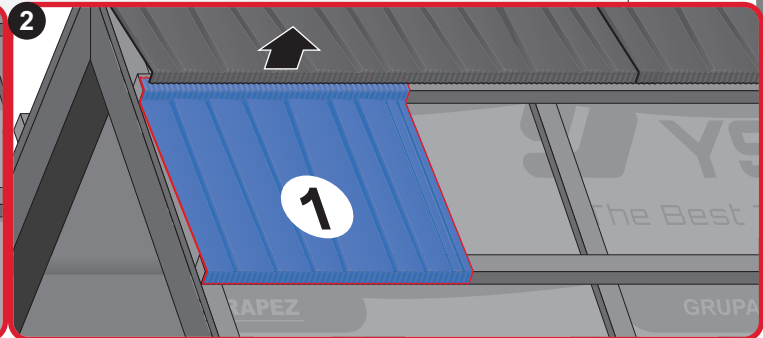
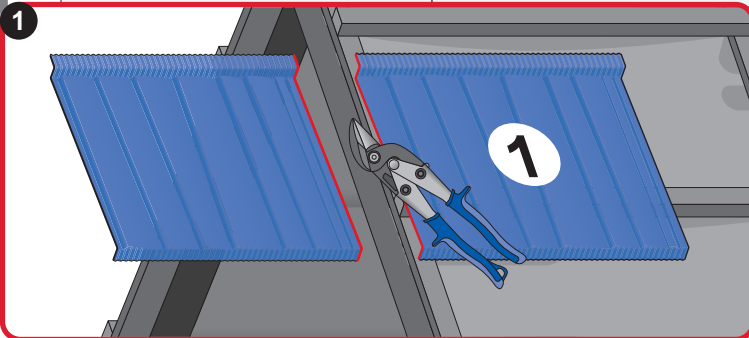
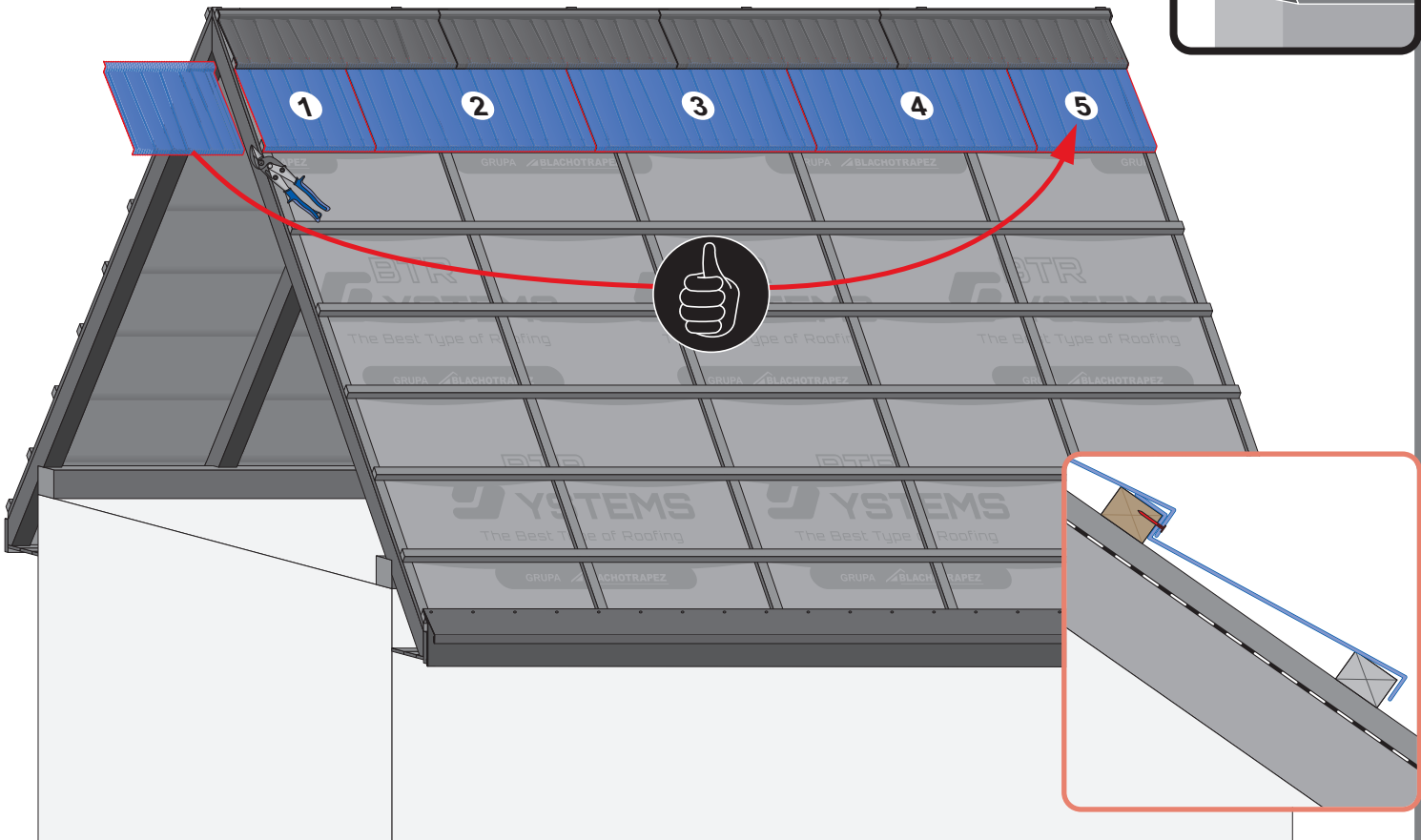
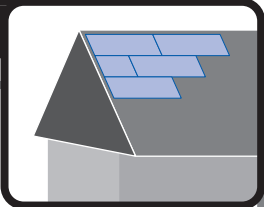

5c

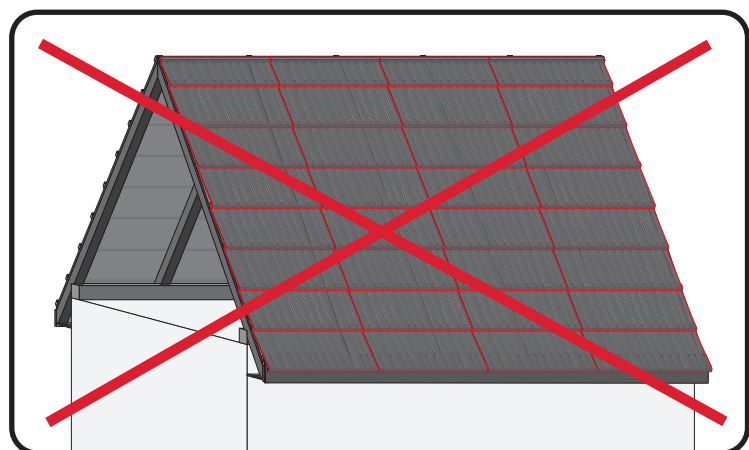
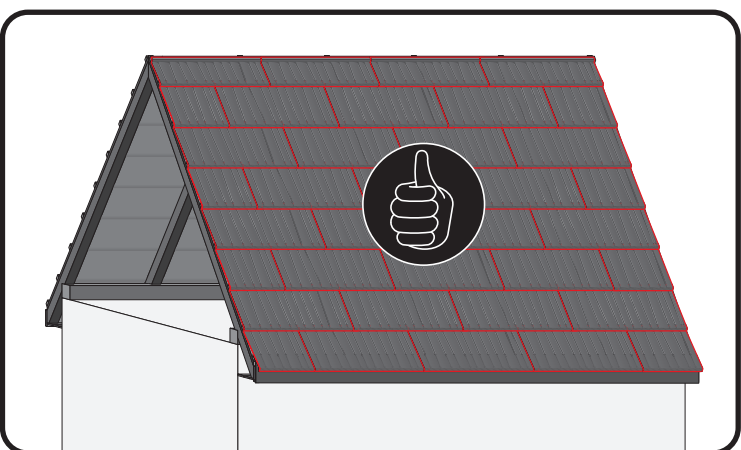
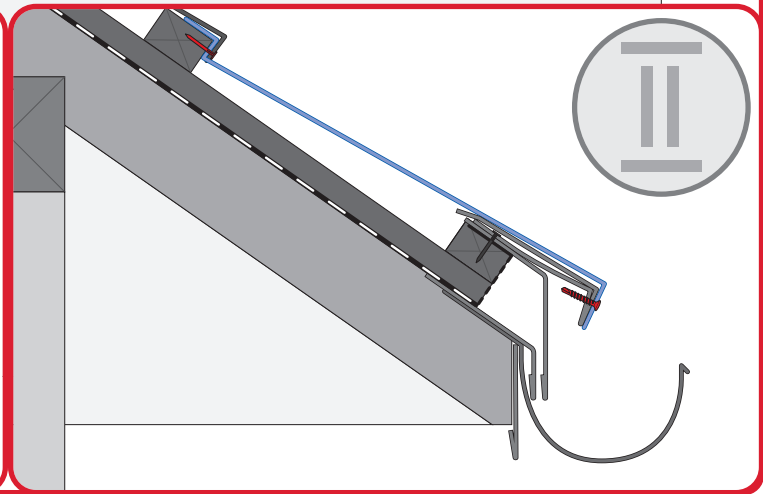
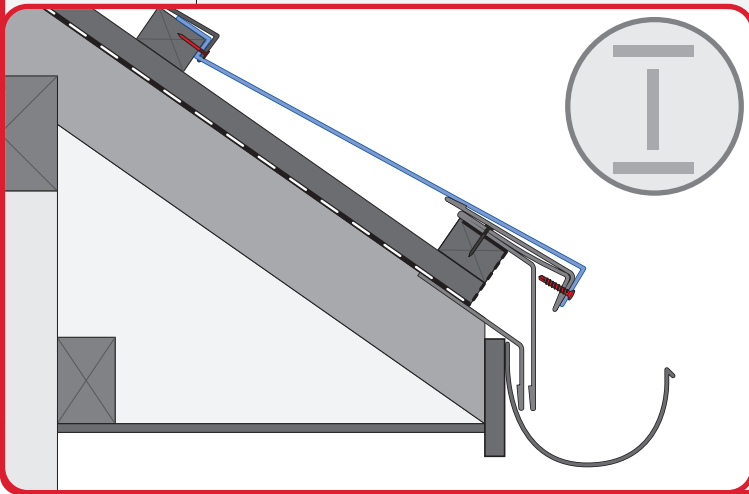
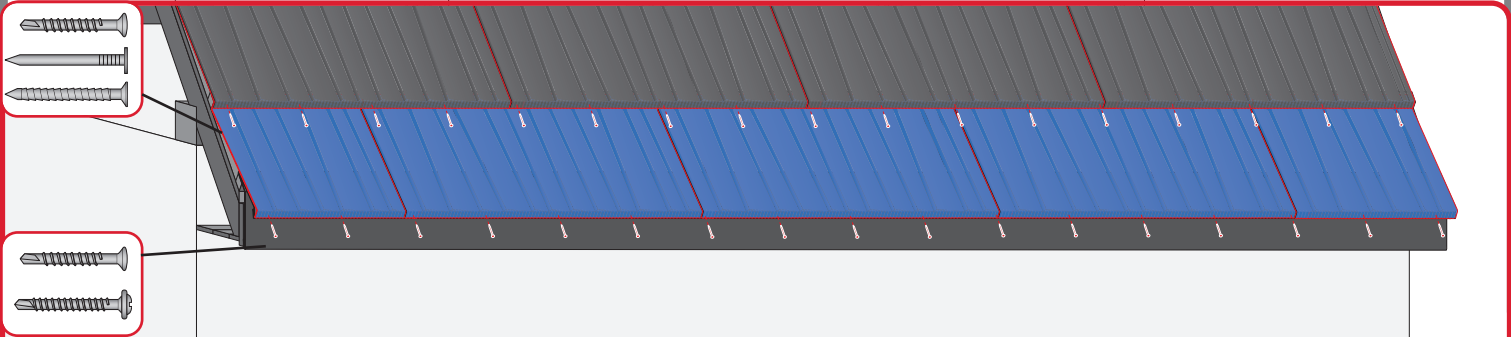
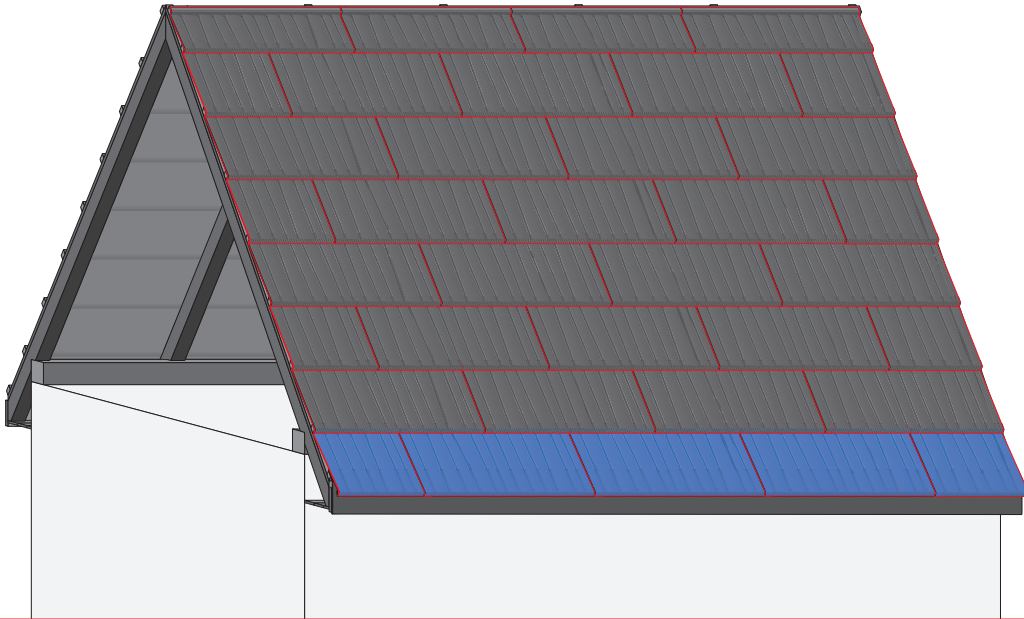
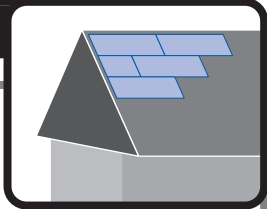

6a

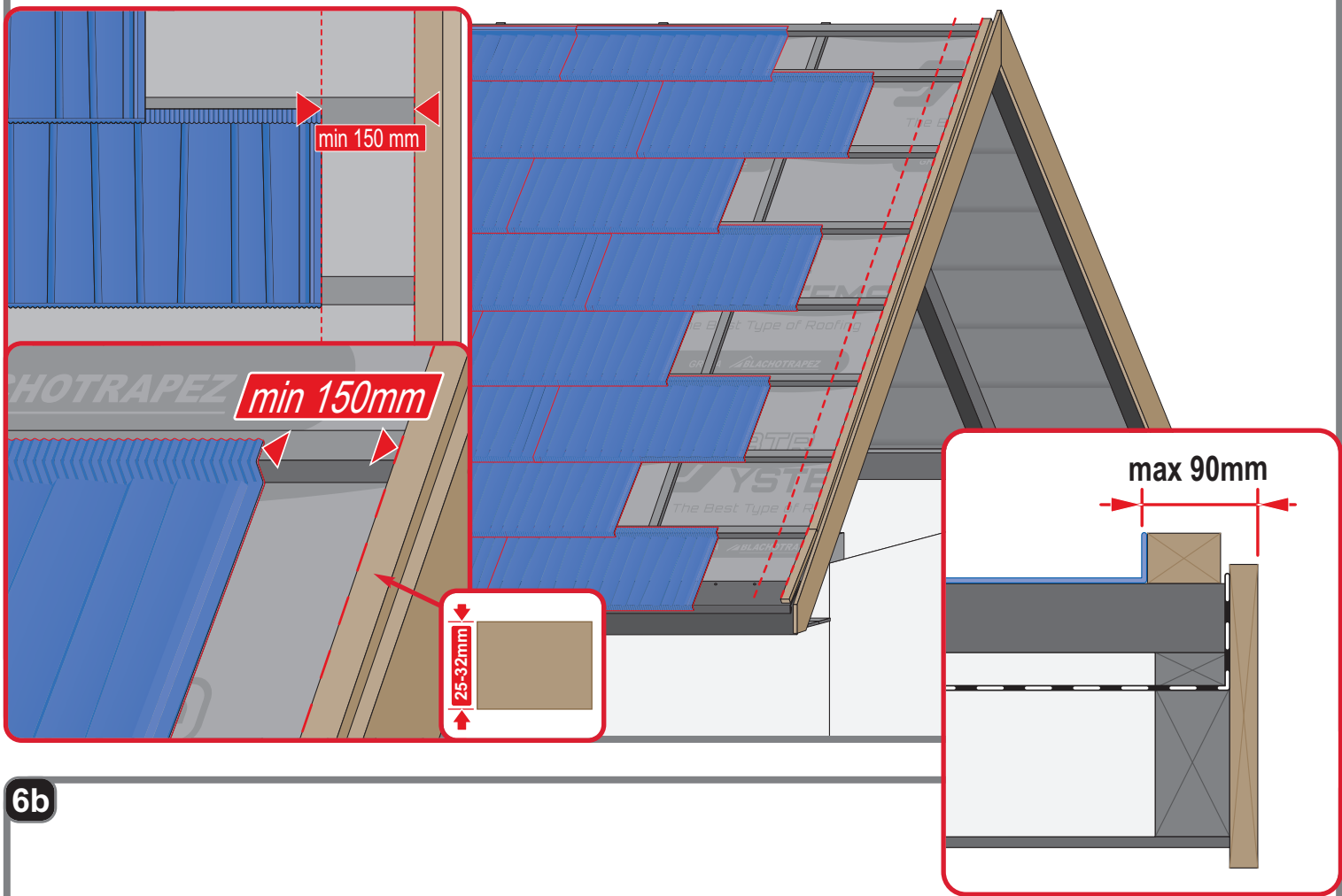
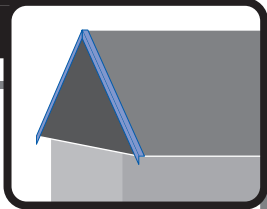

6b

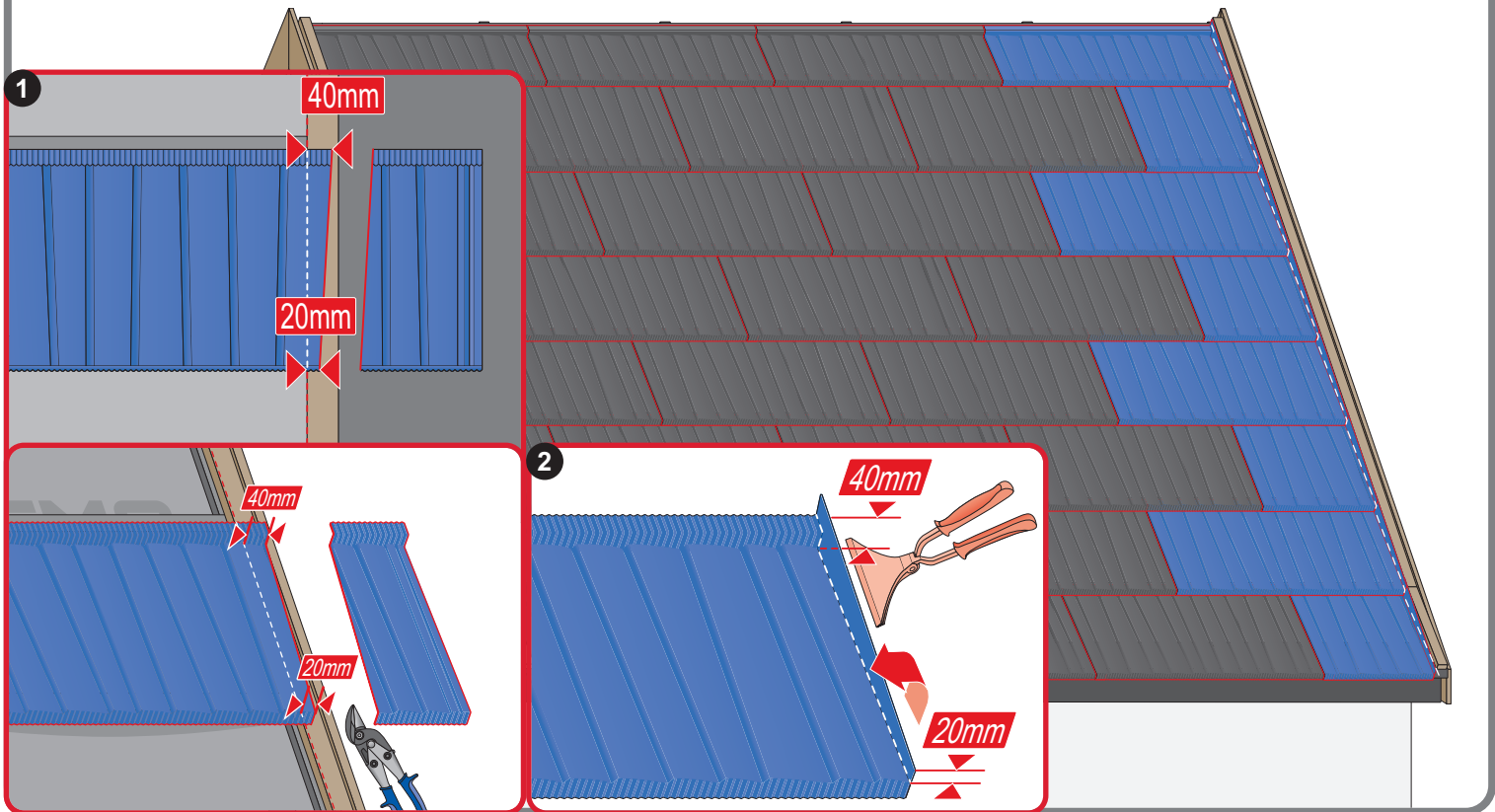

6c

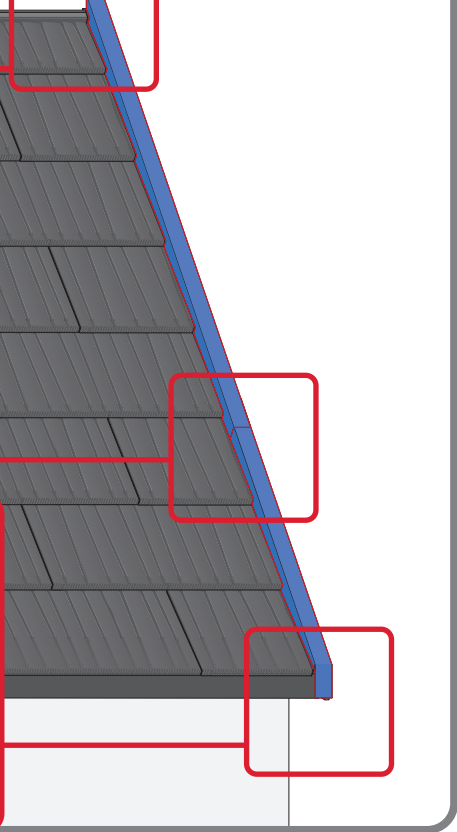
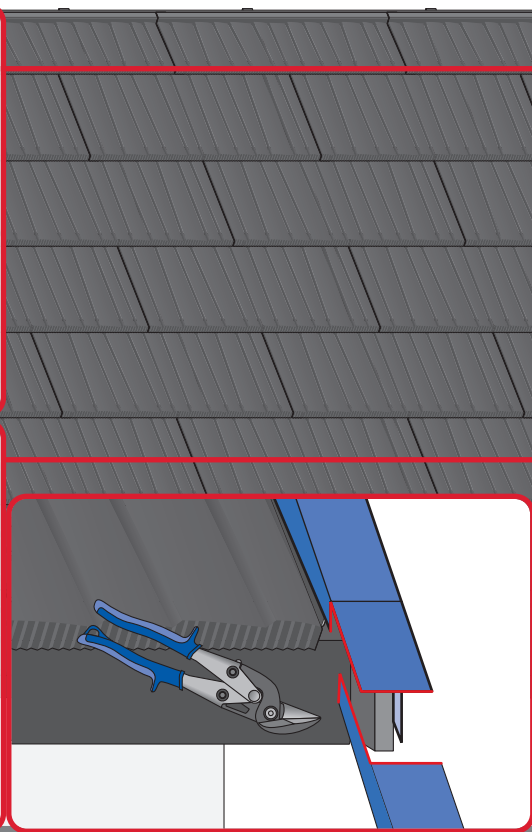
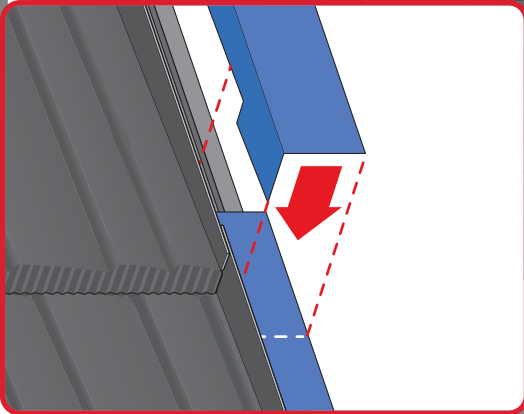
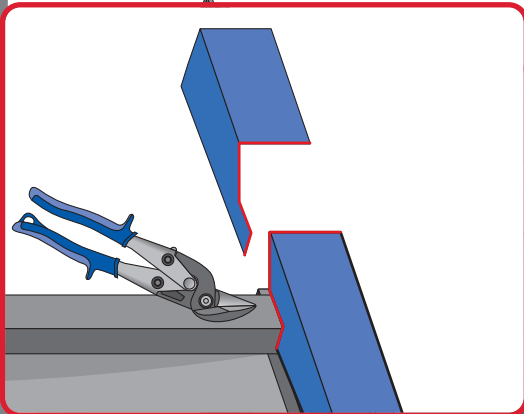
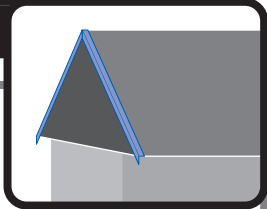

6d

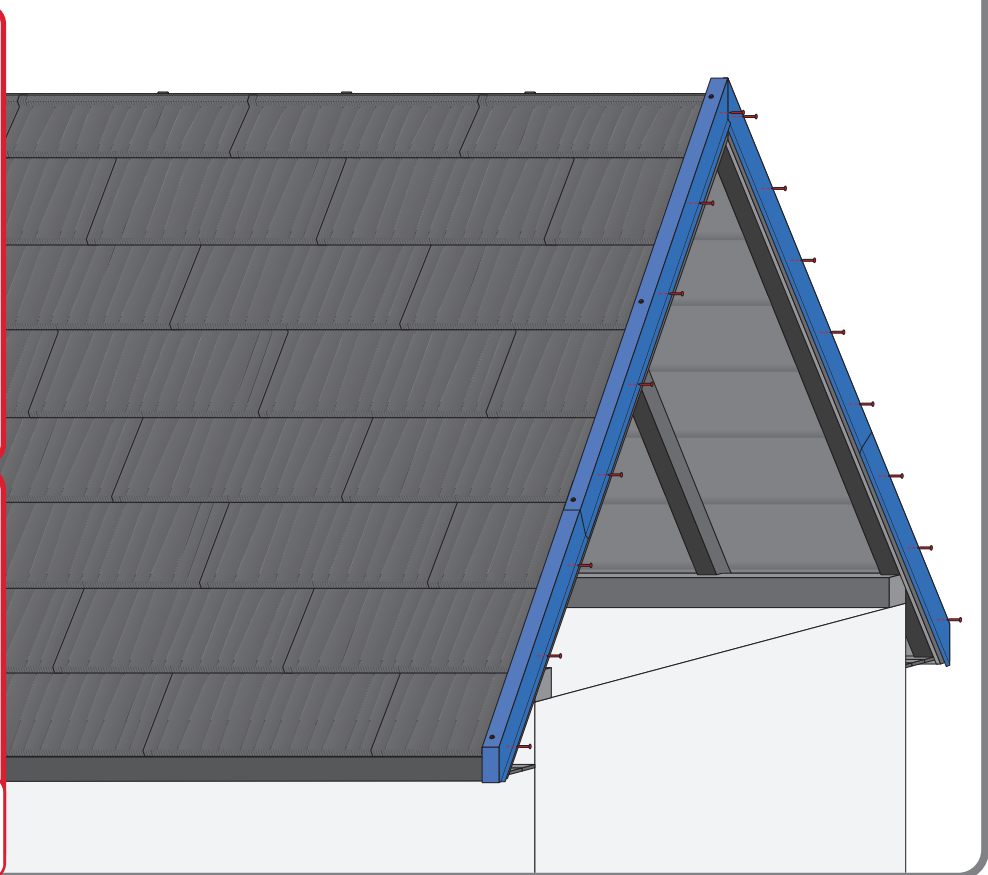
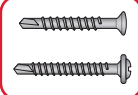
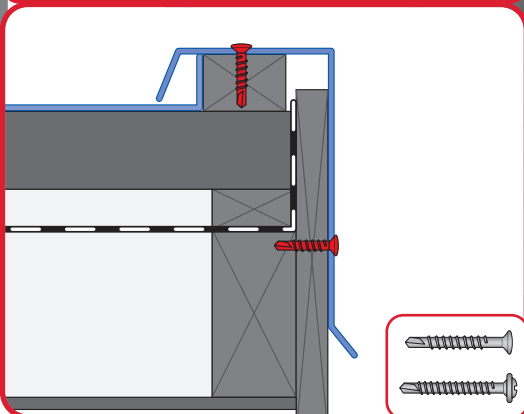
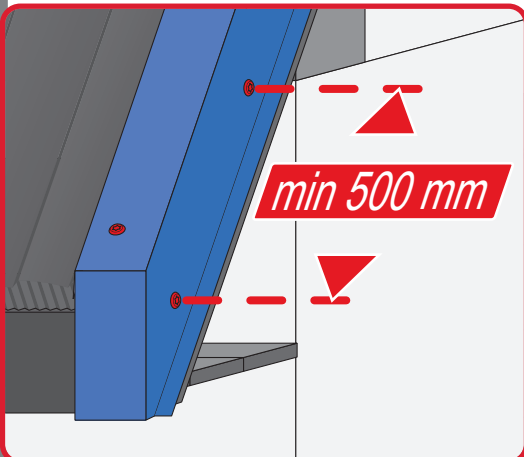

7a

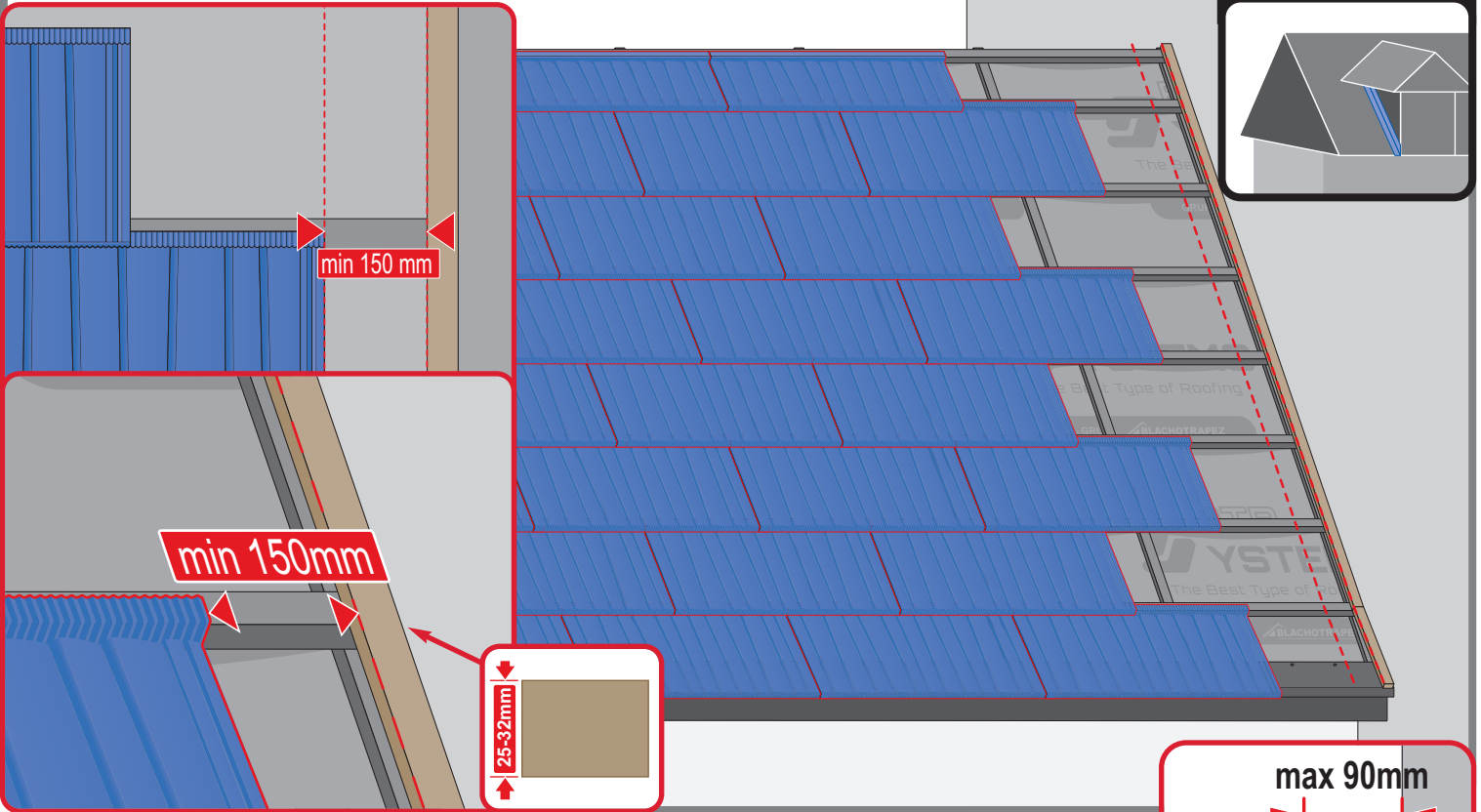

7b

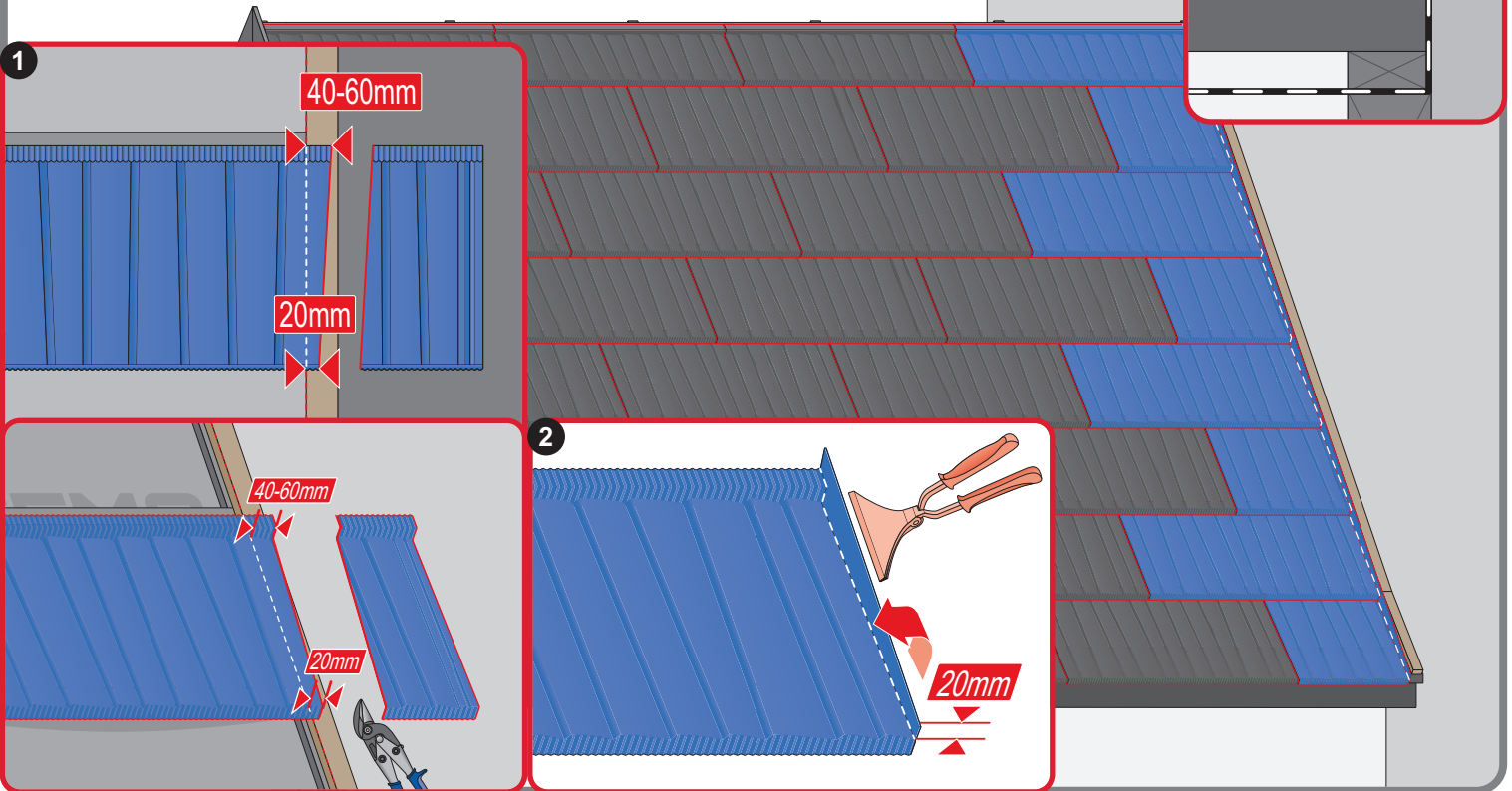

7c

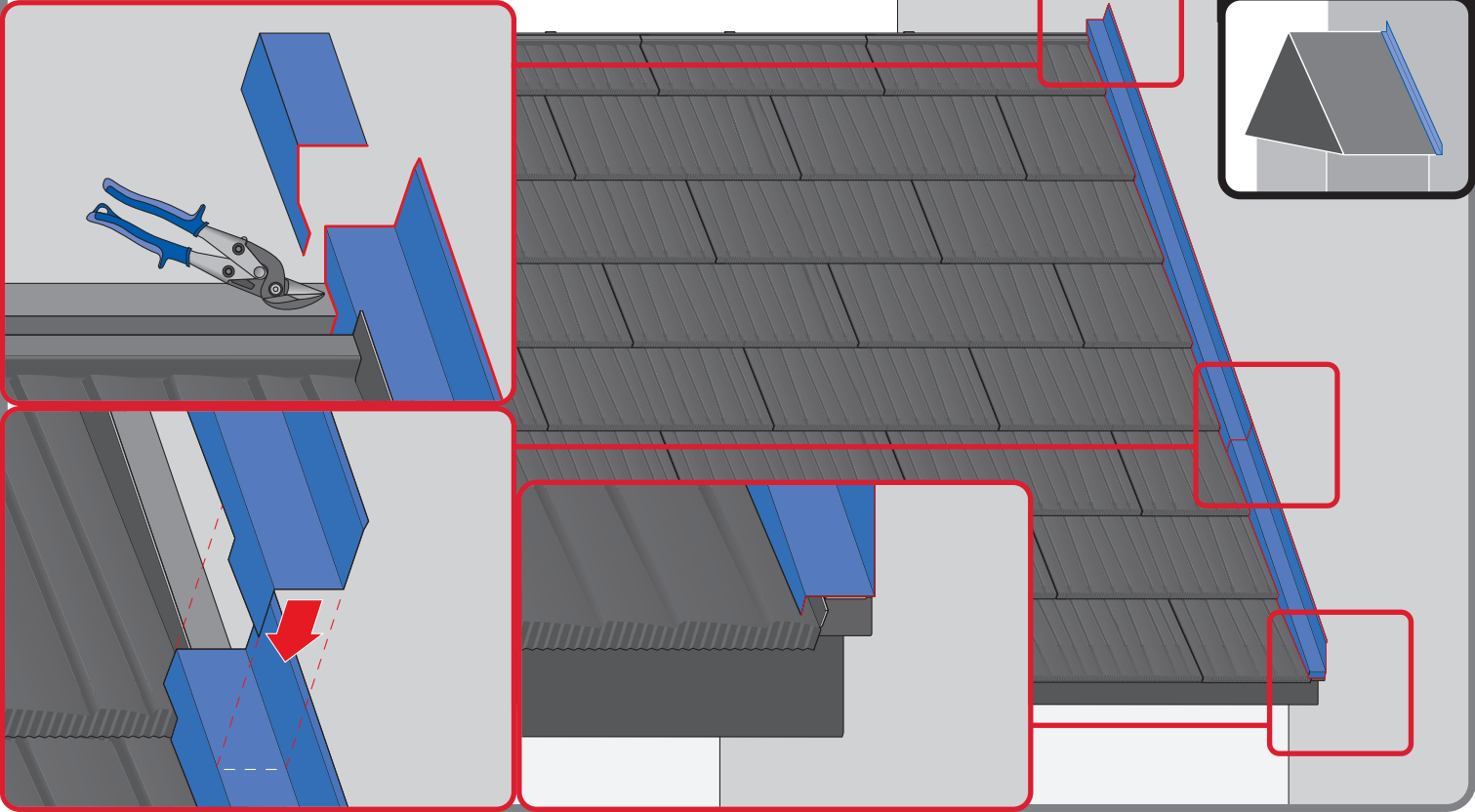

7d

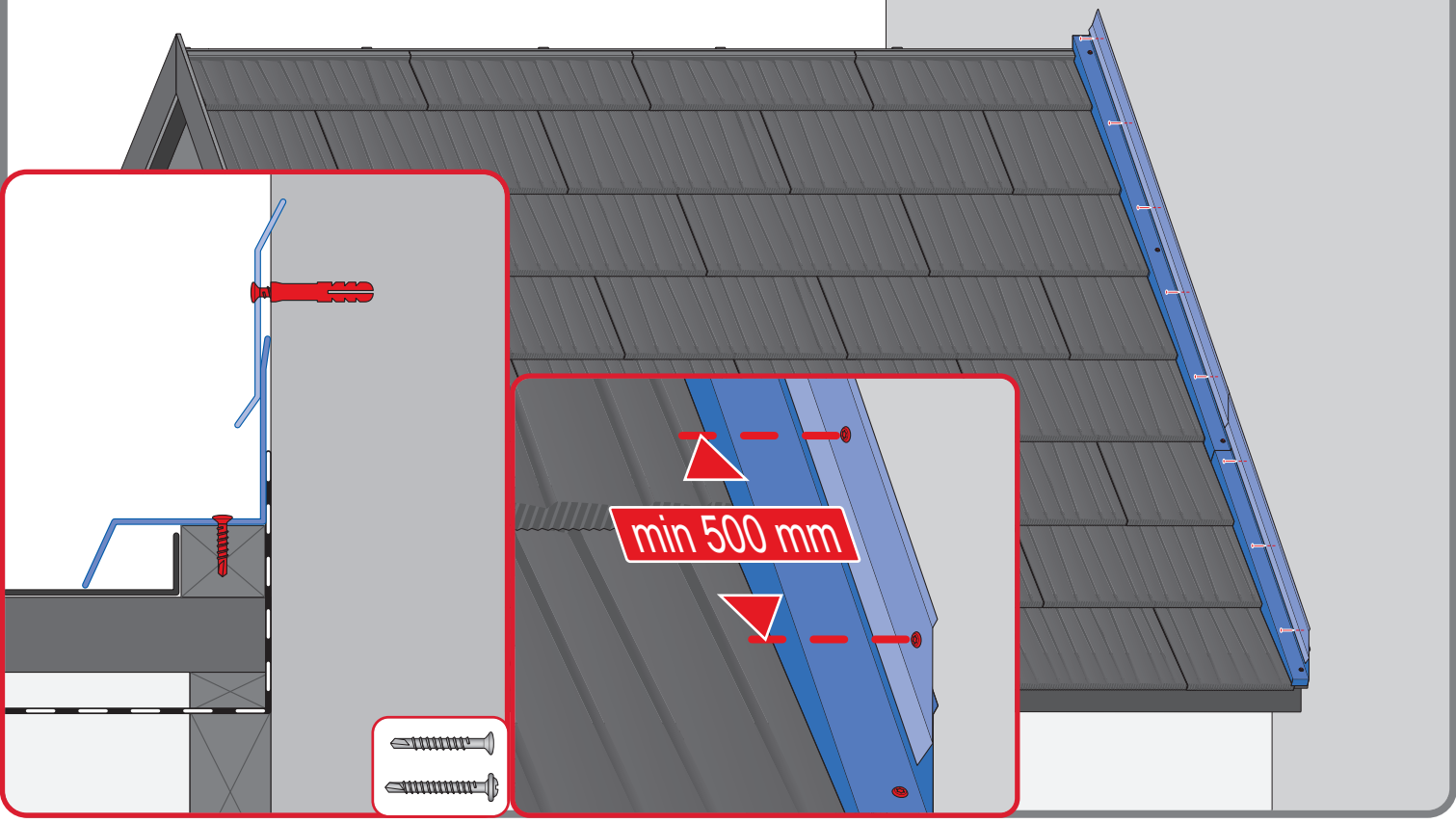

8a

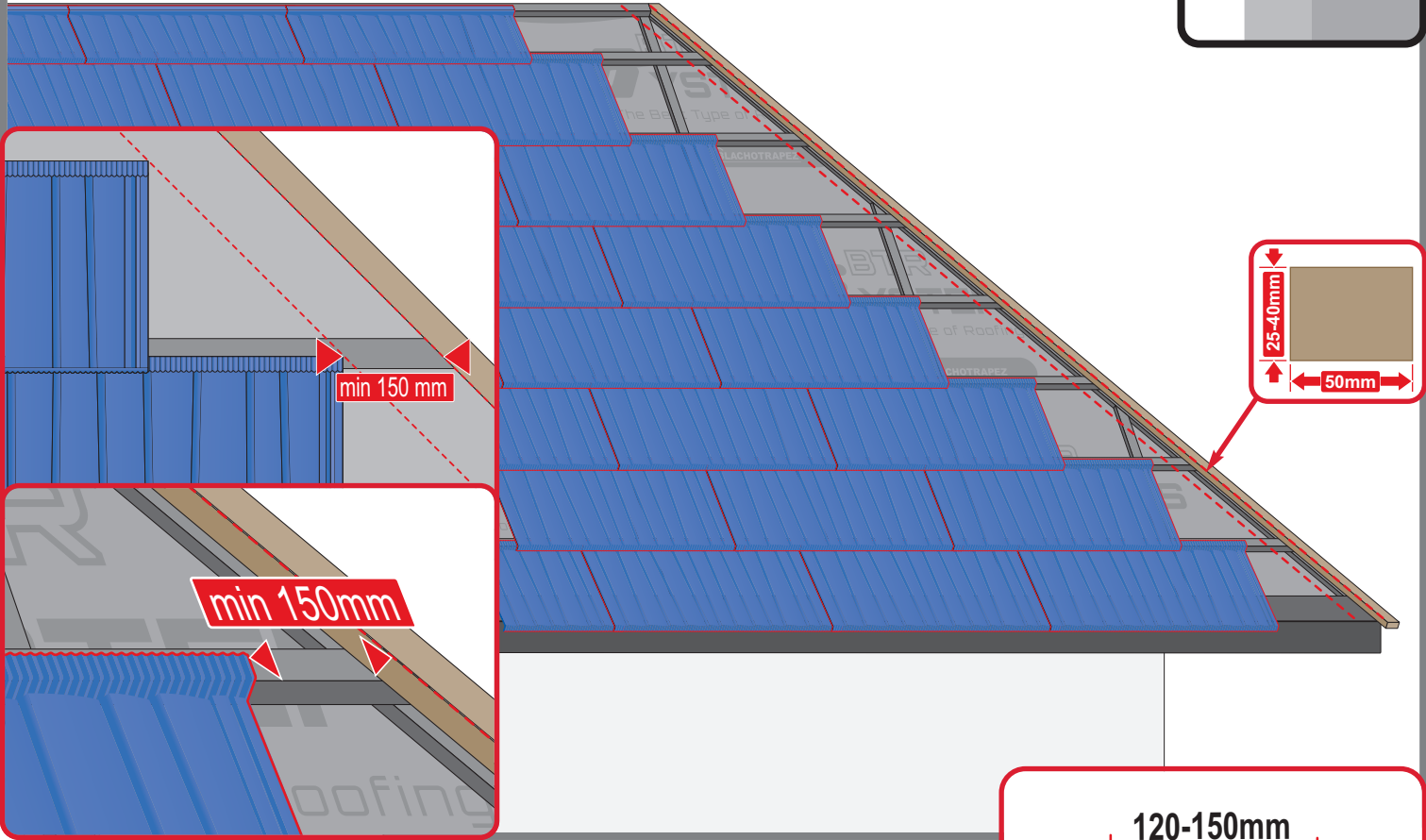
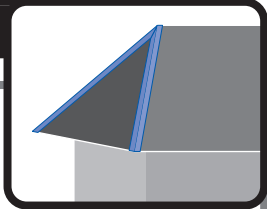

8b

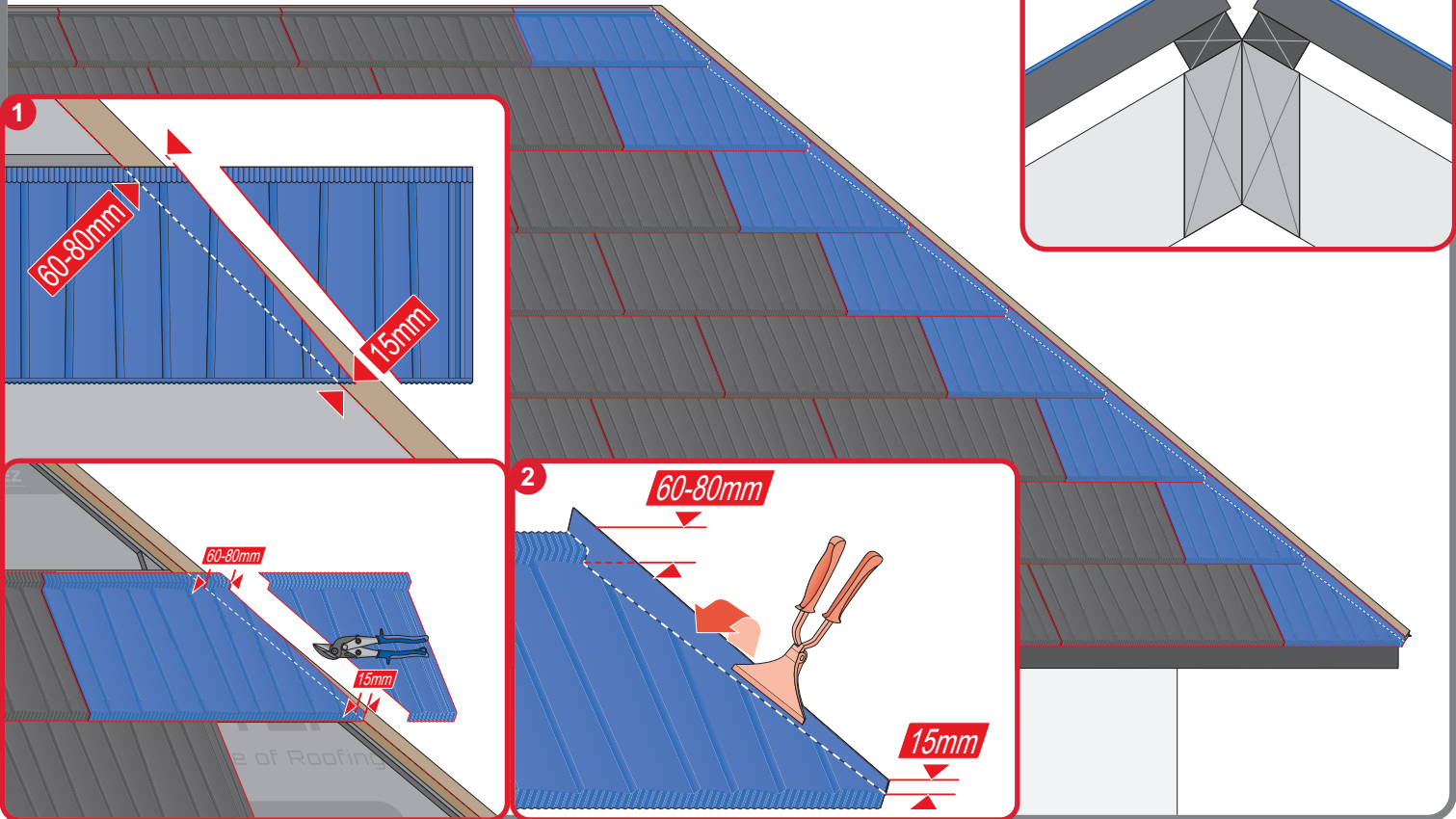

8c

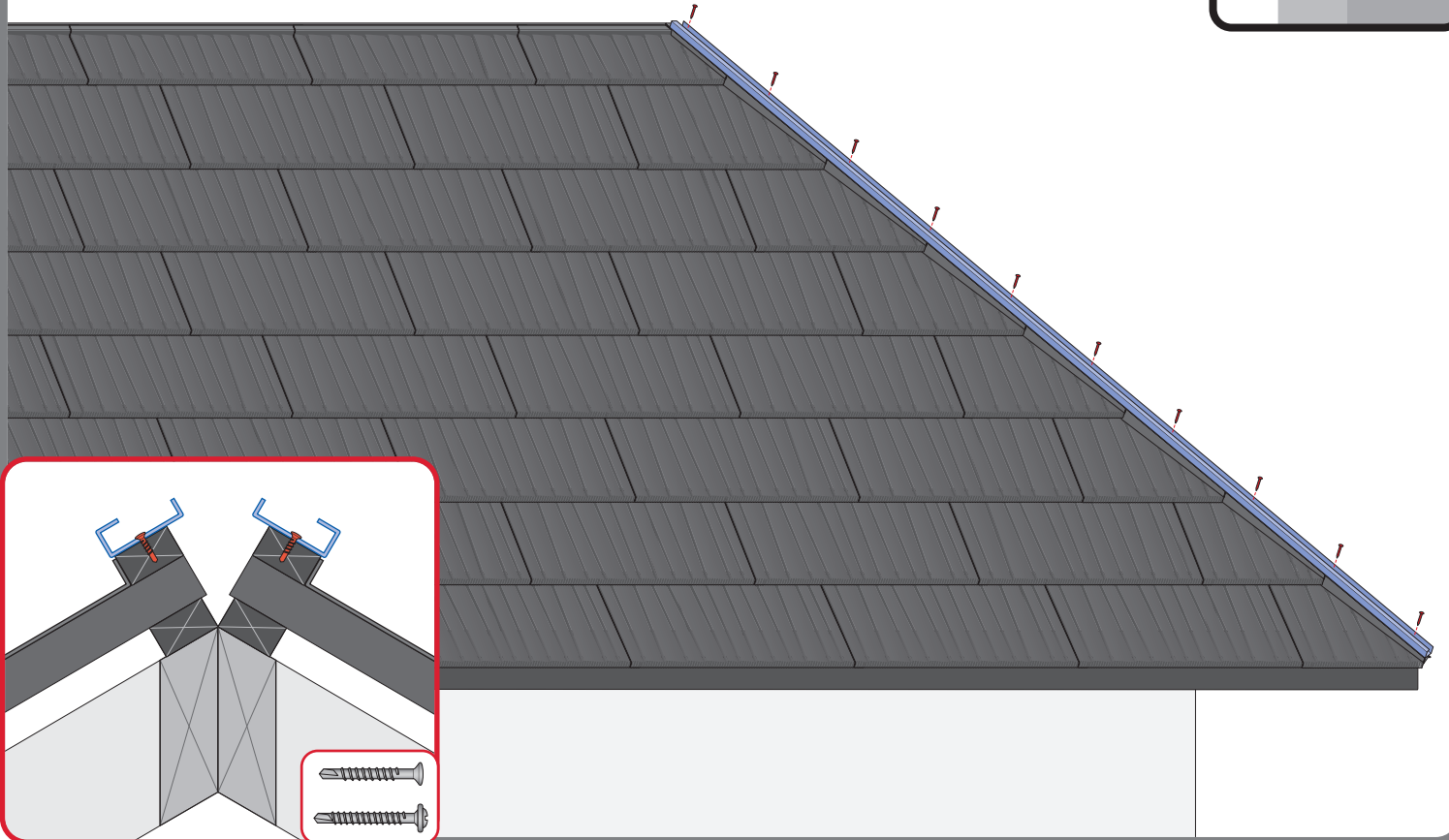
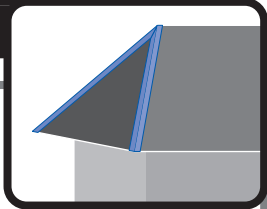

8d

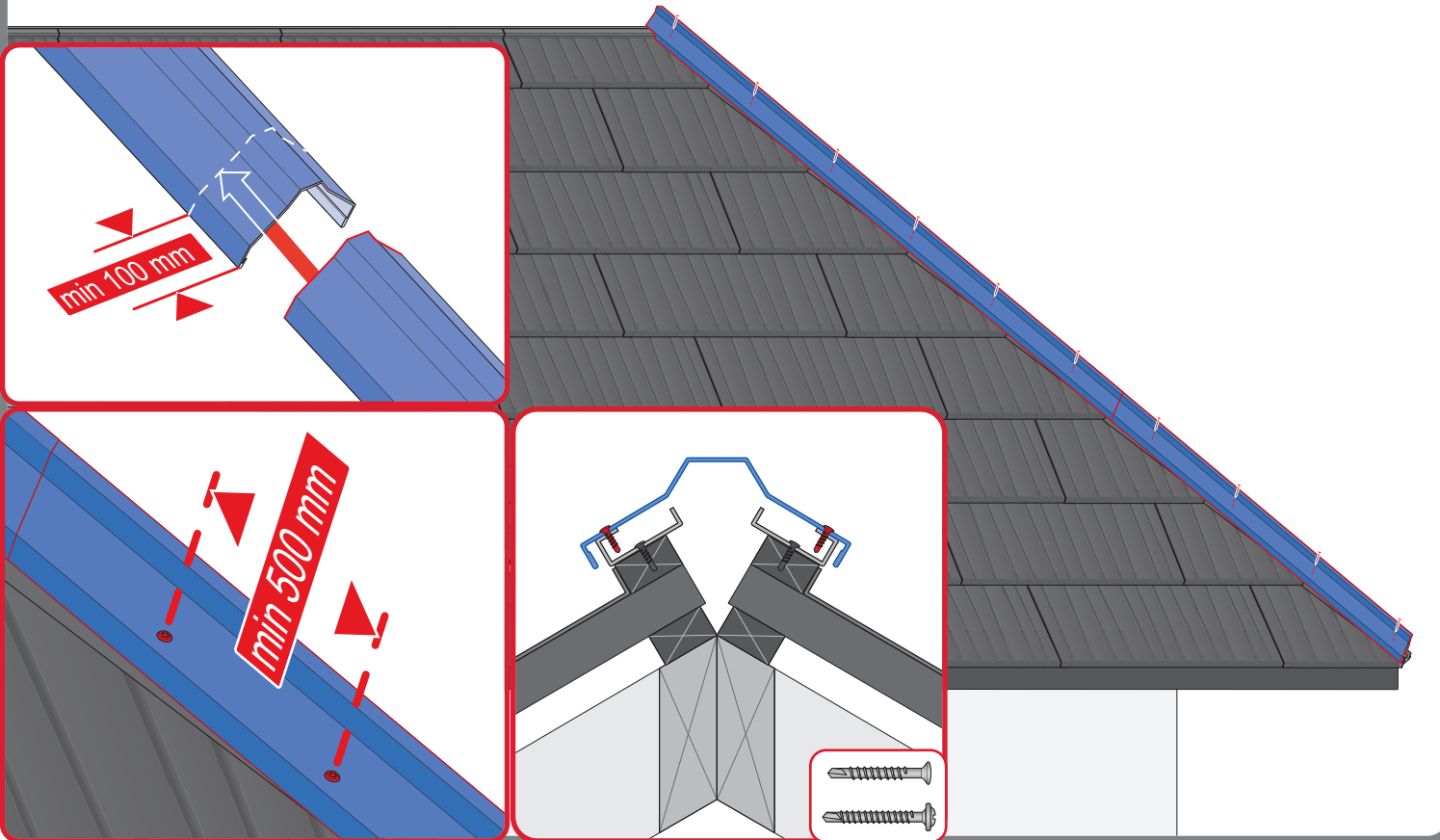

9a

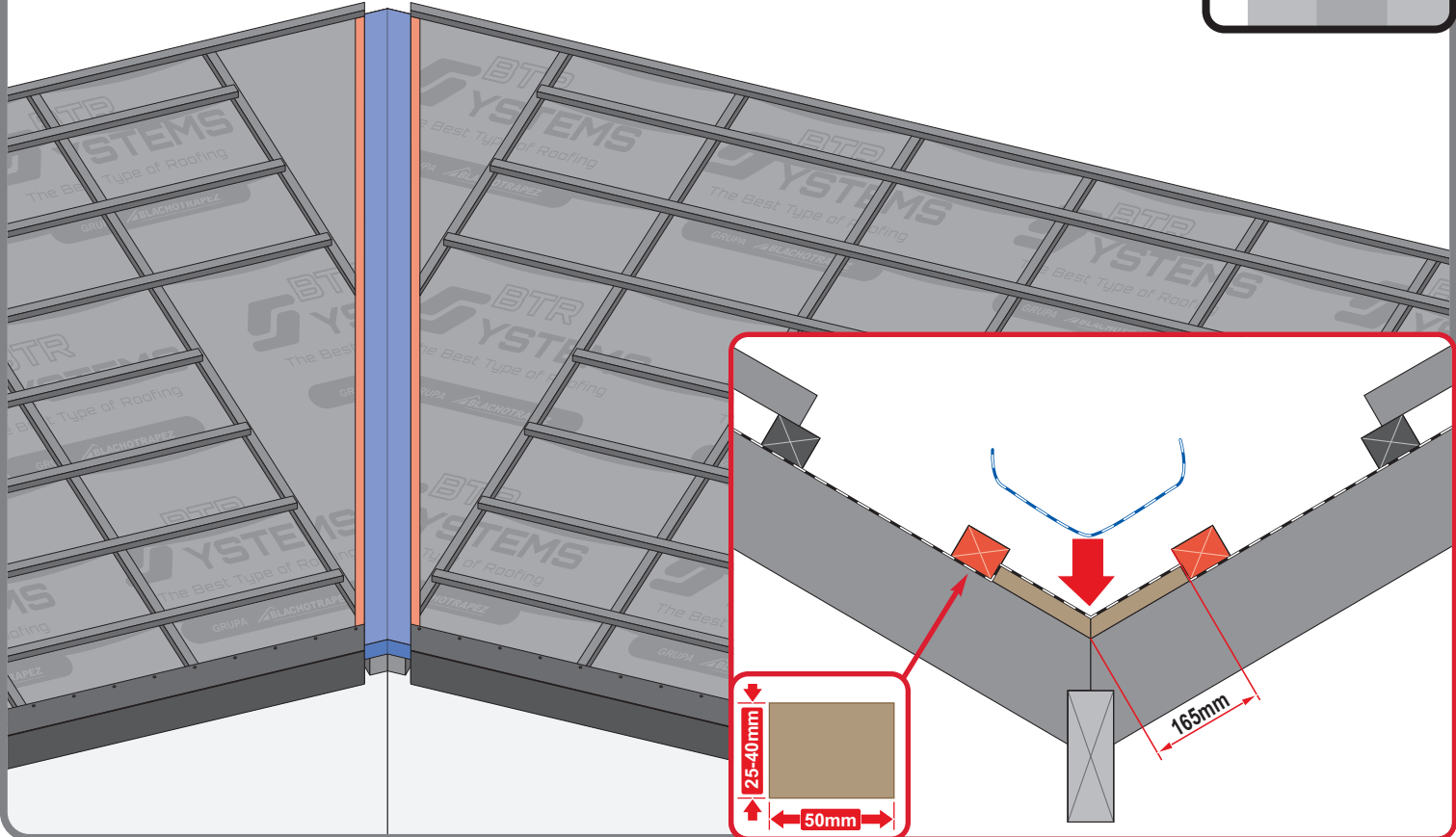
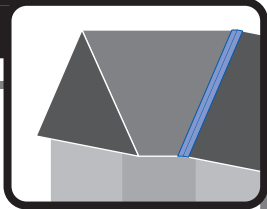

9b

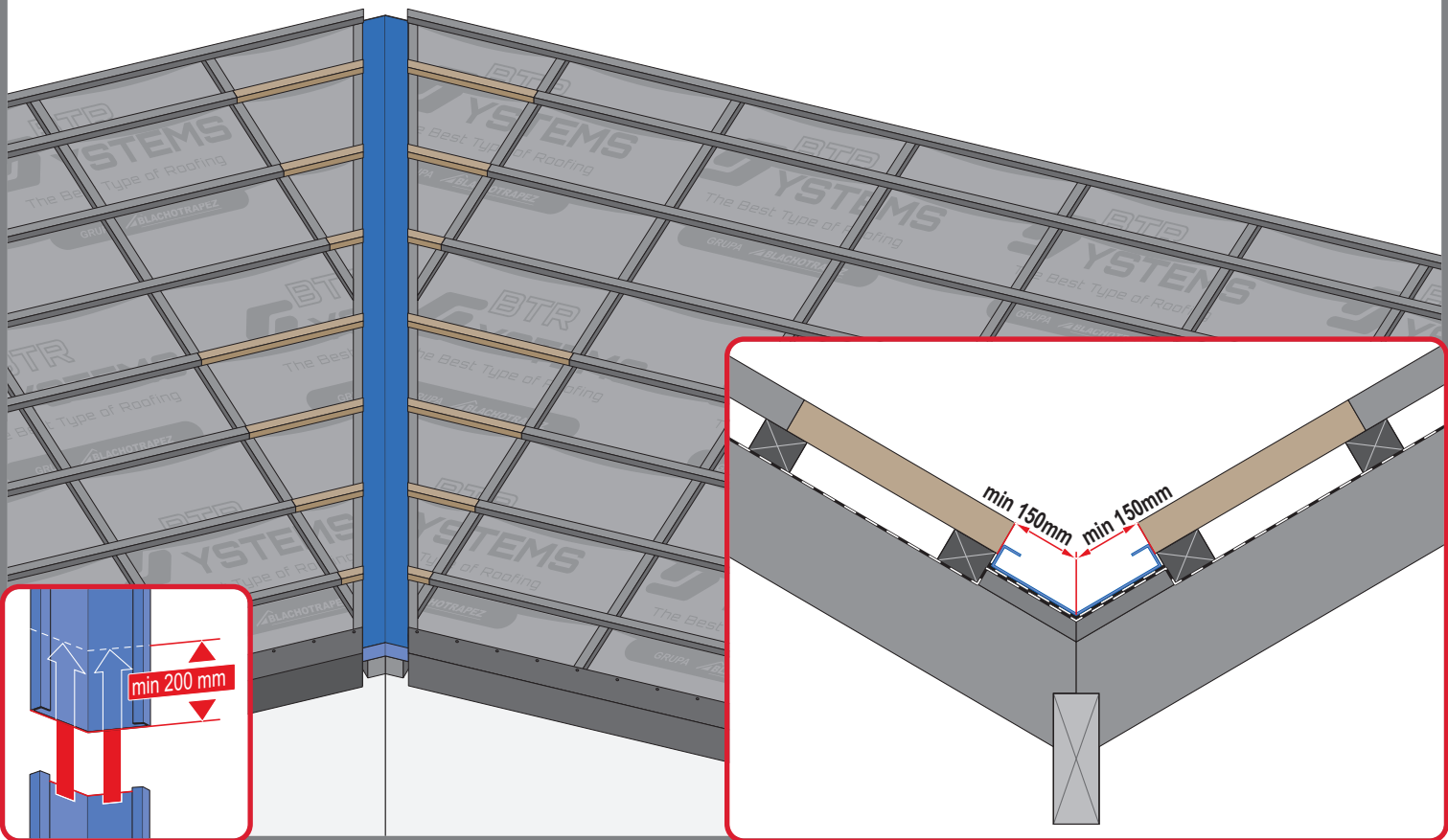

9c

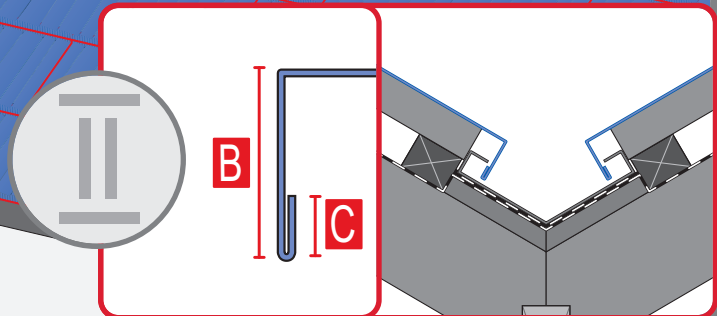
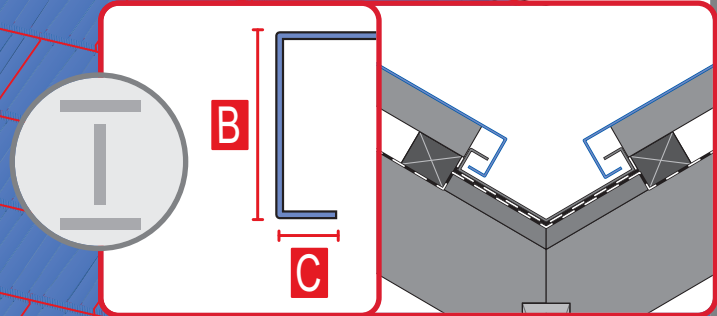
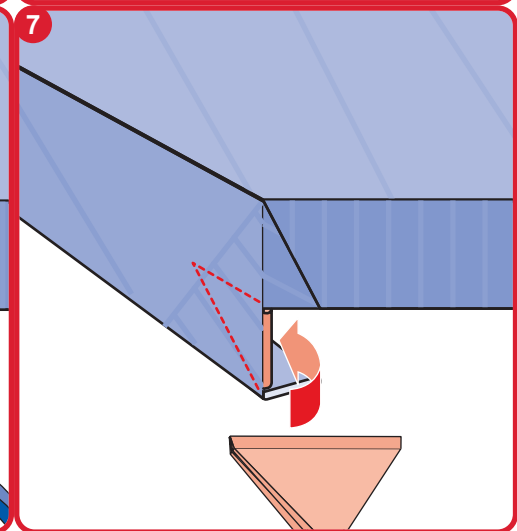
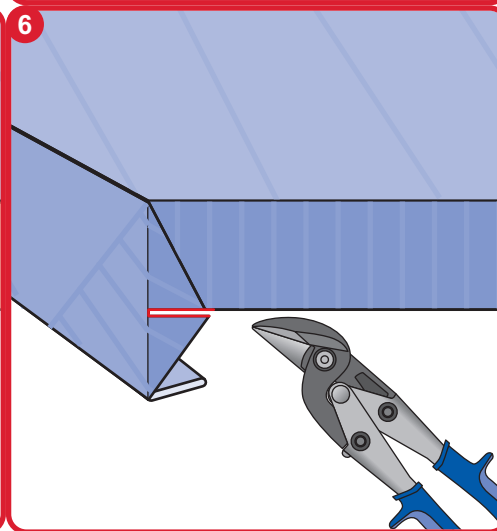
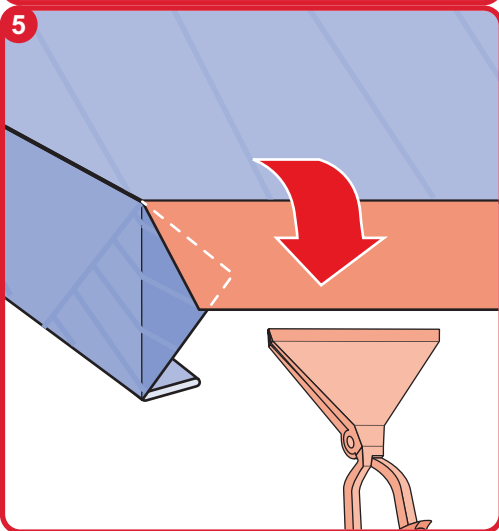
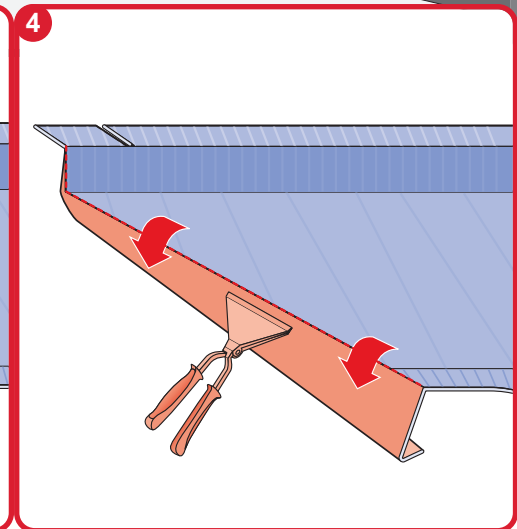
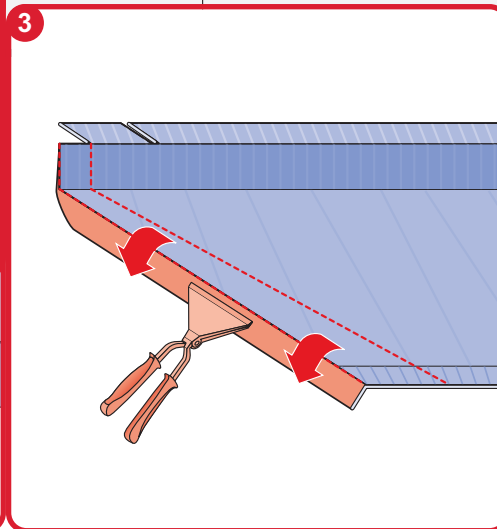
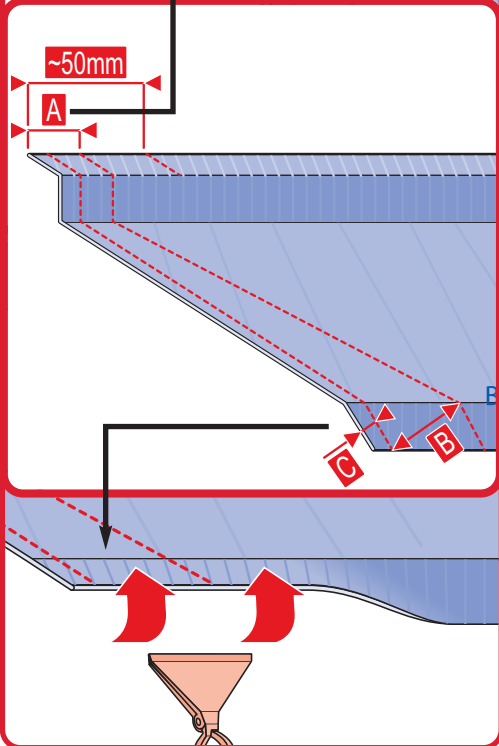
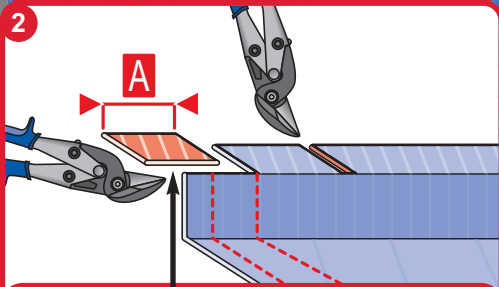
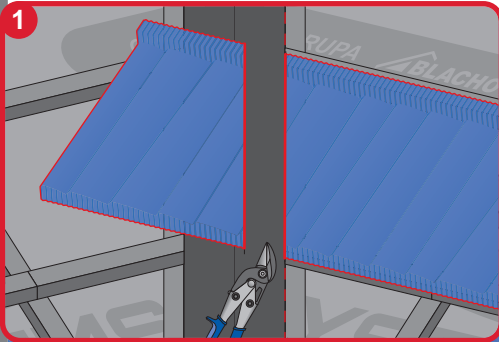
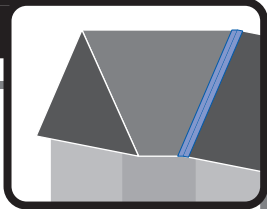

10a

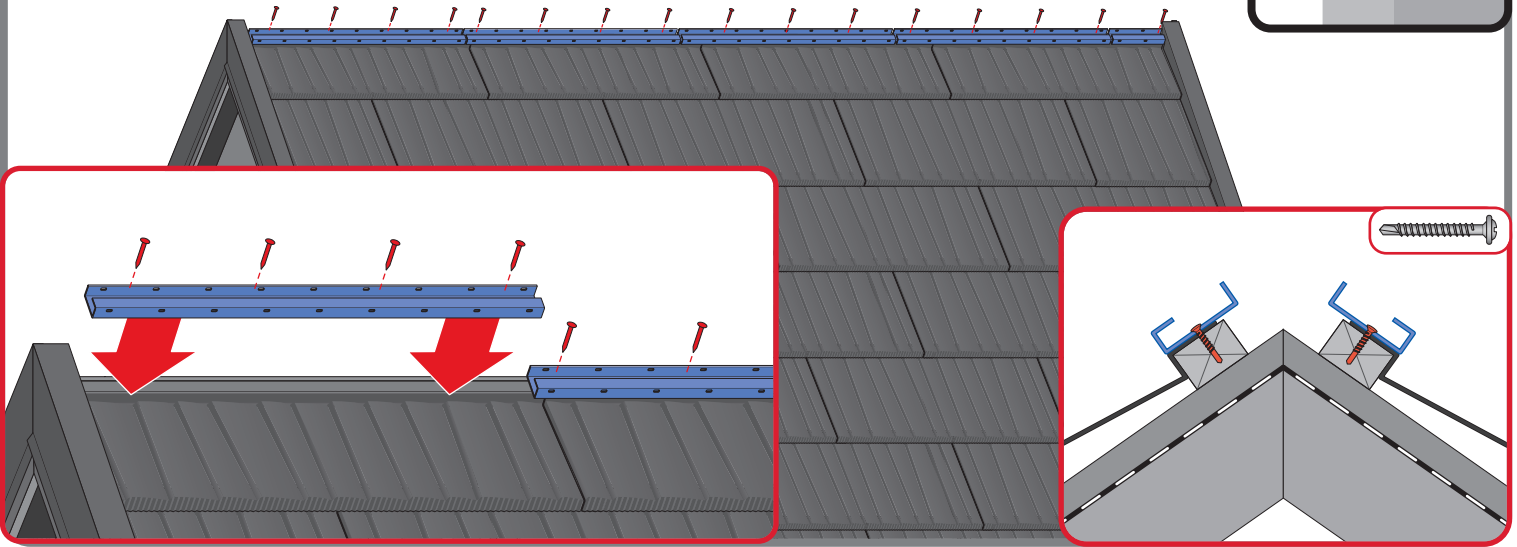

10b

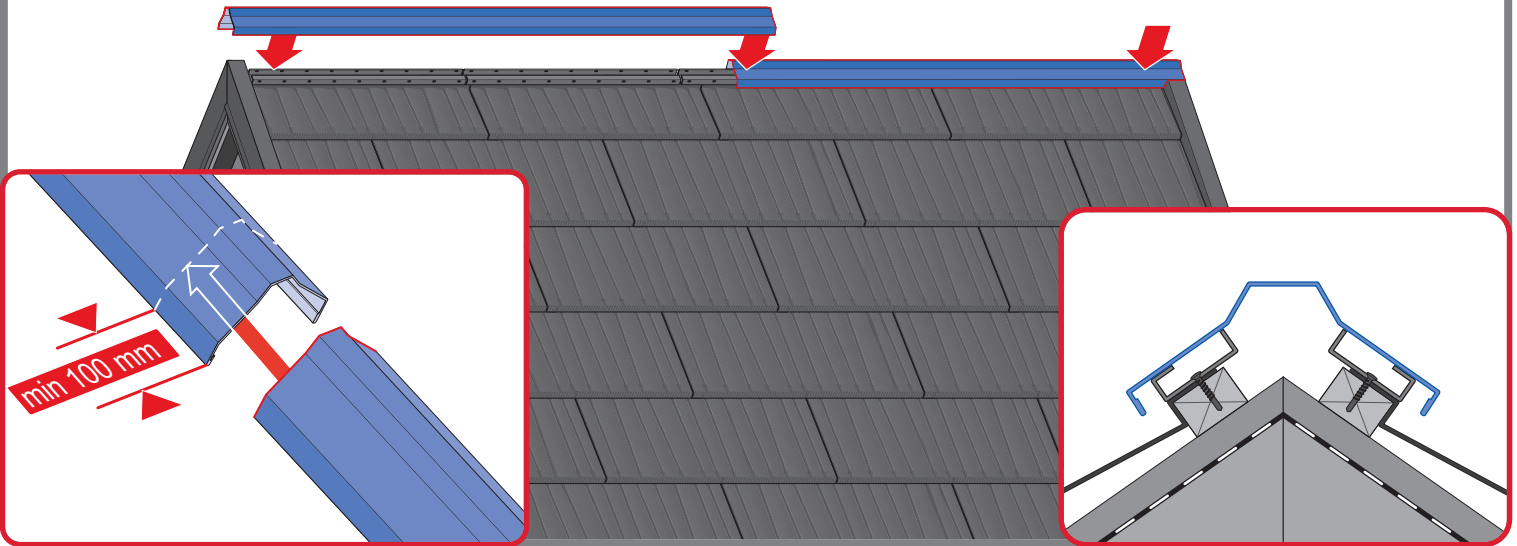

10c

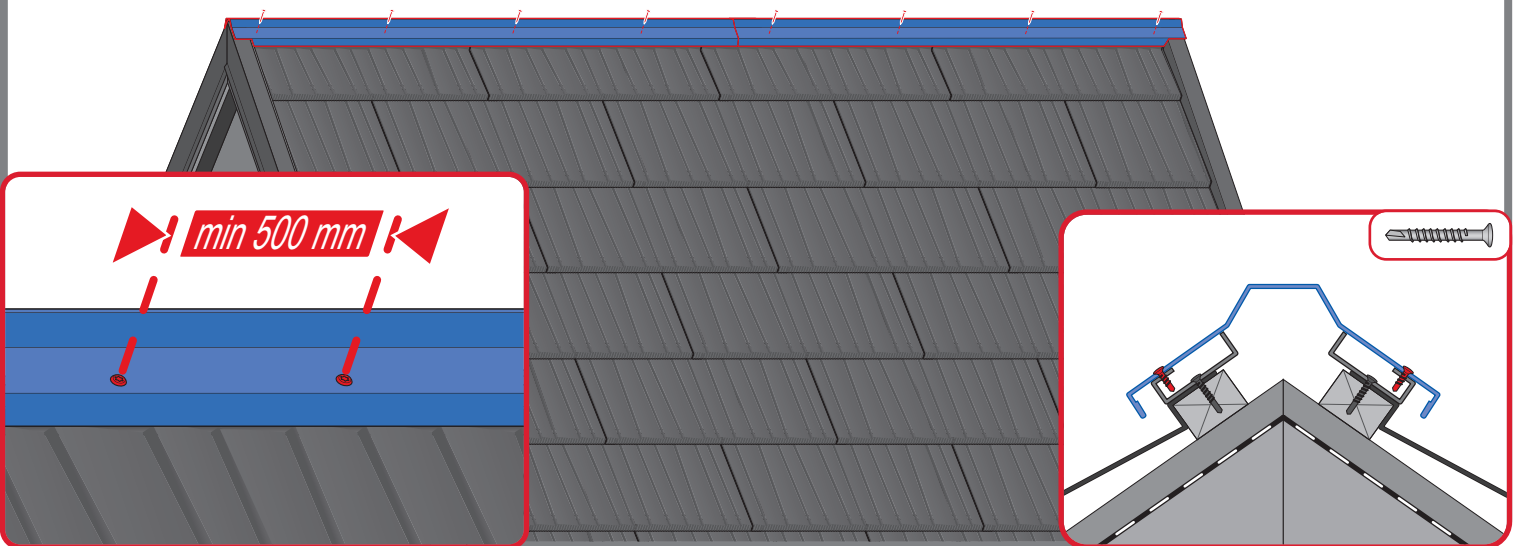

11a

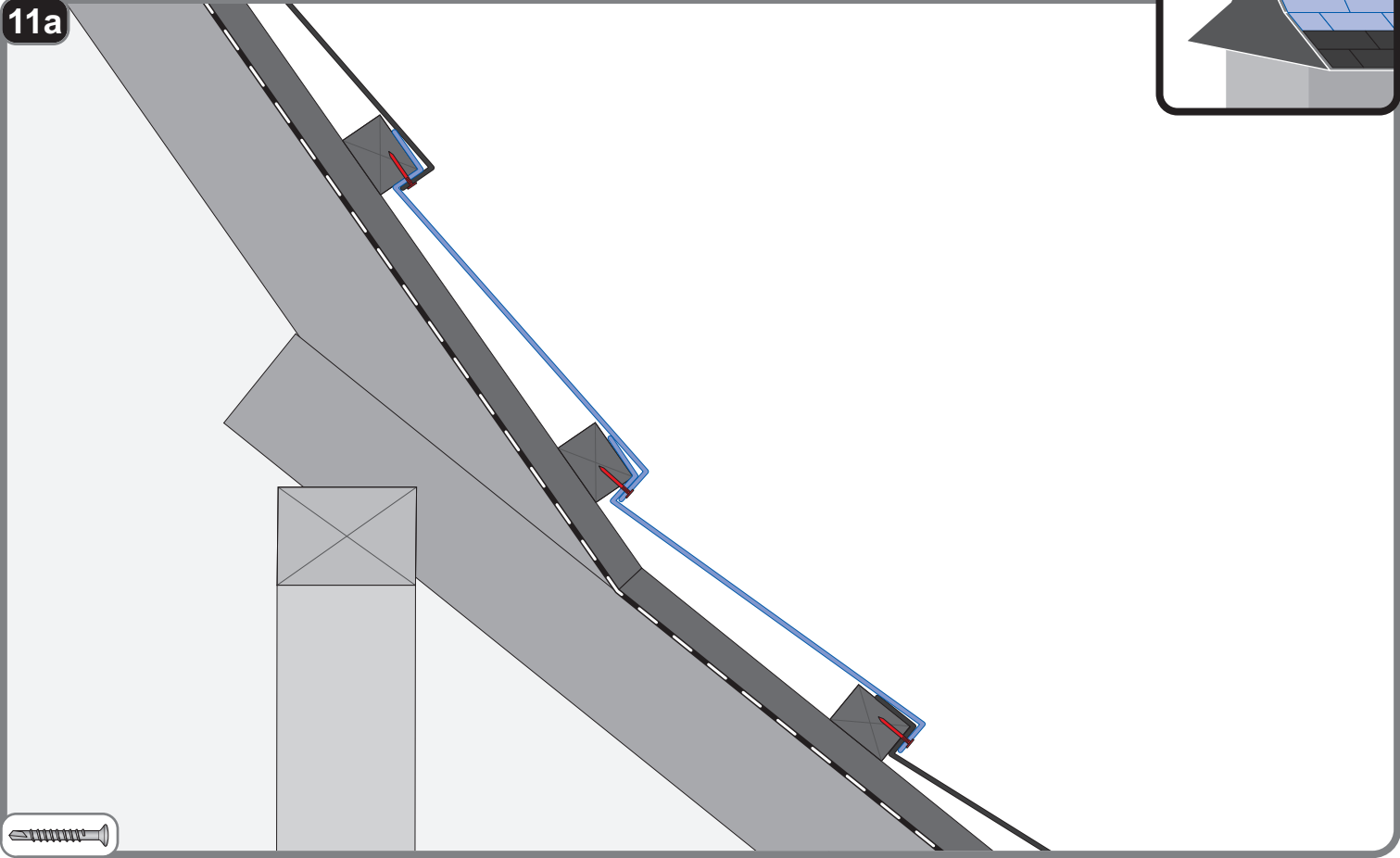
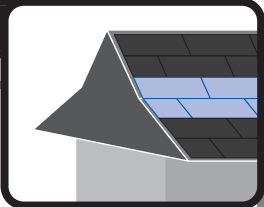

11b

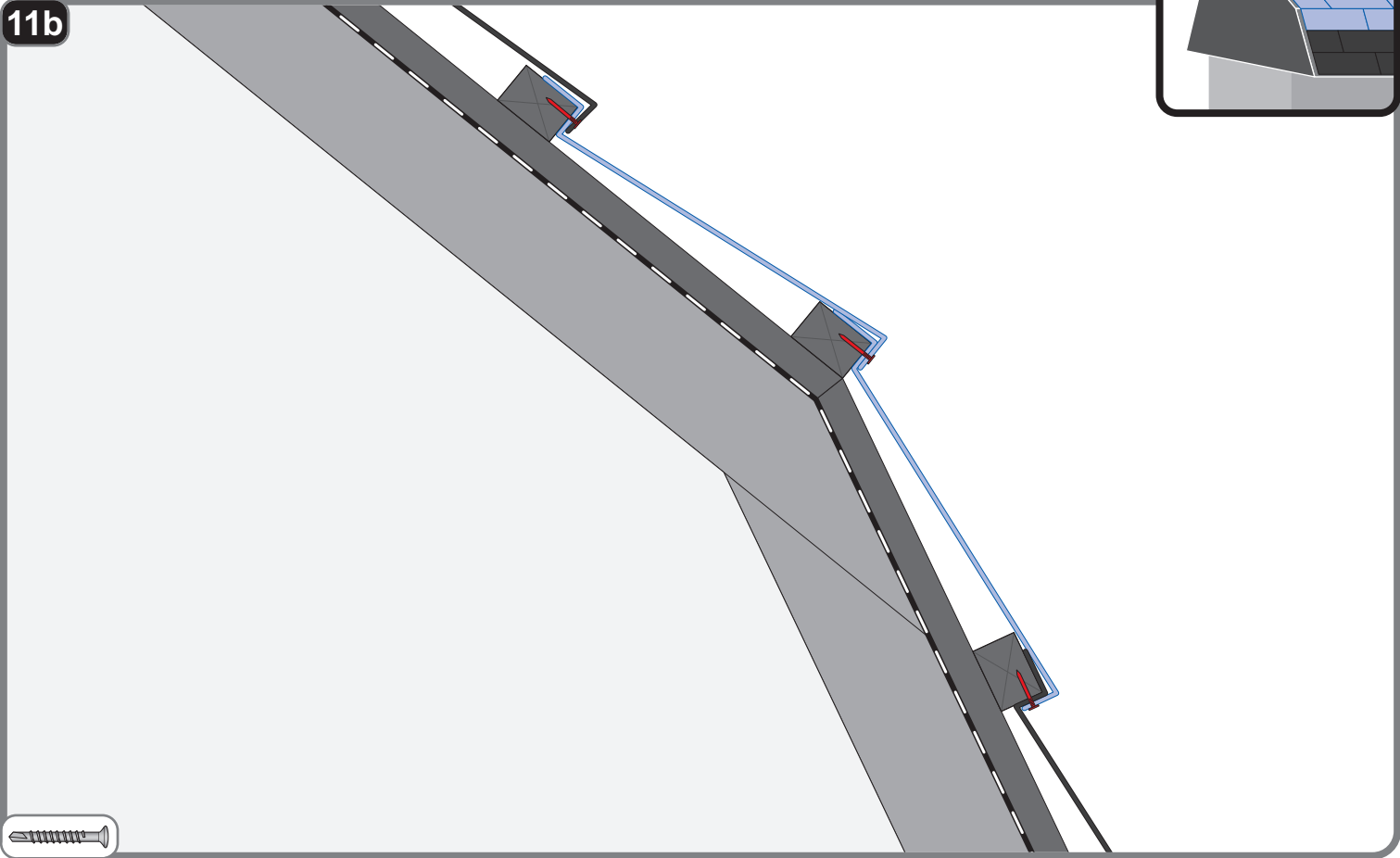
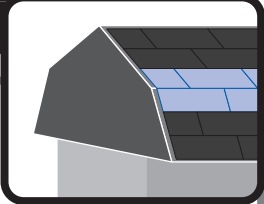

12a

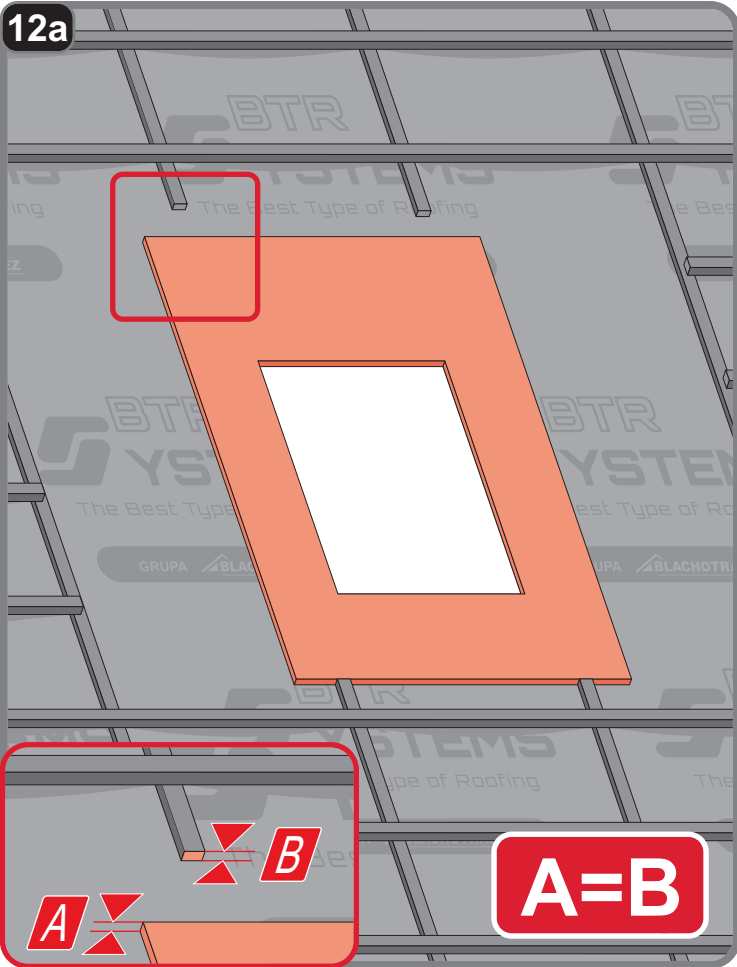

12b

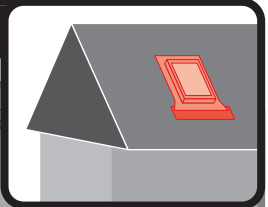
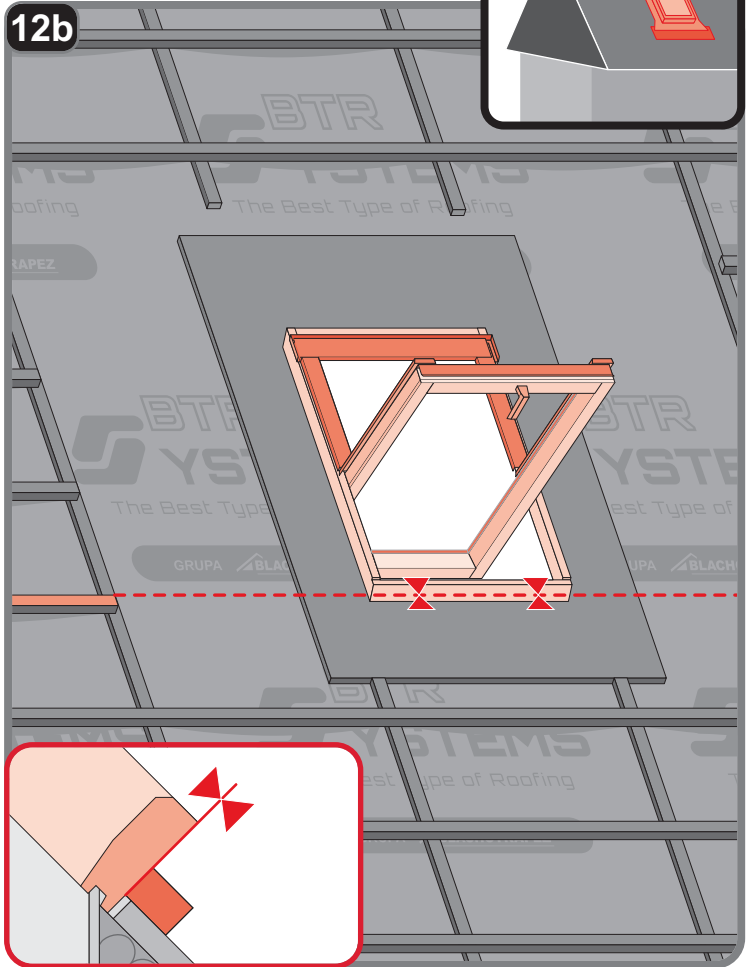

12c

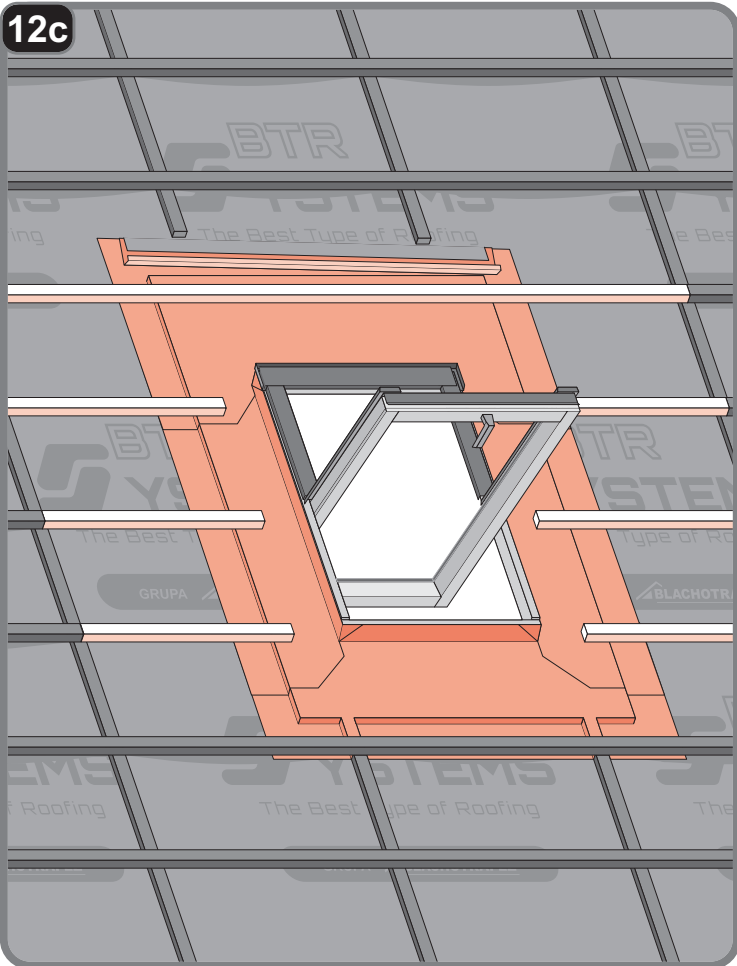

12d

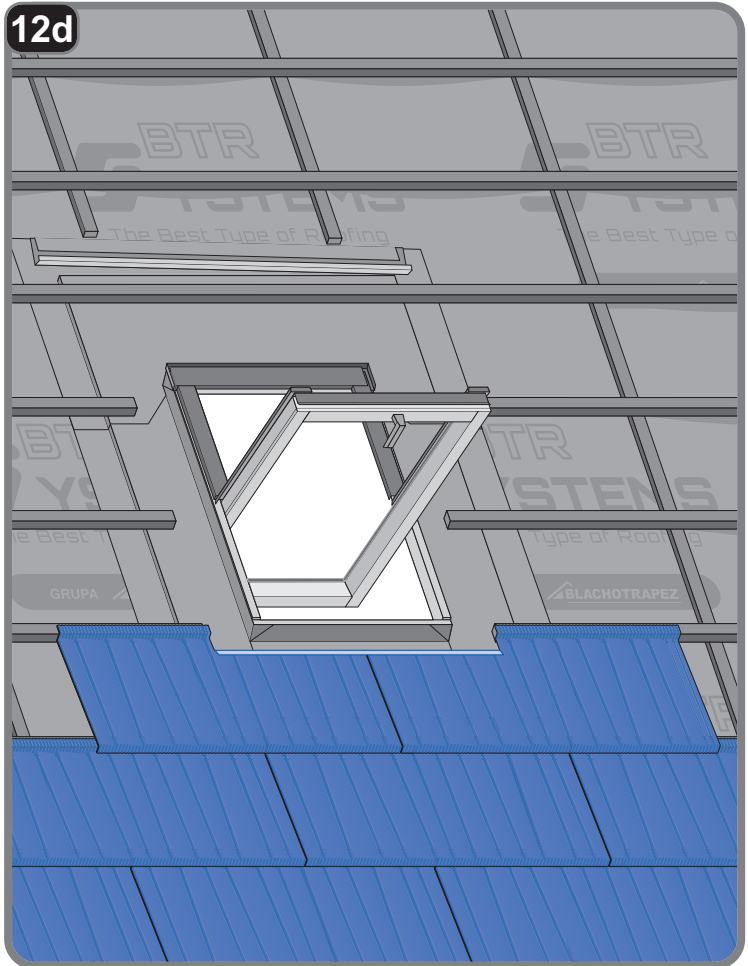

12e

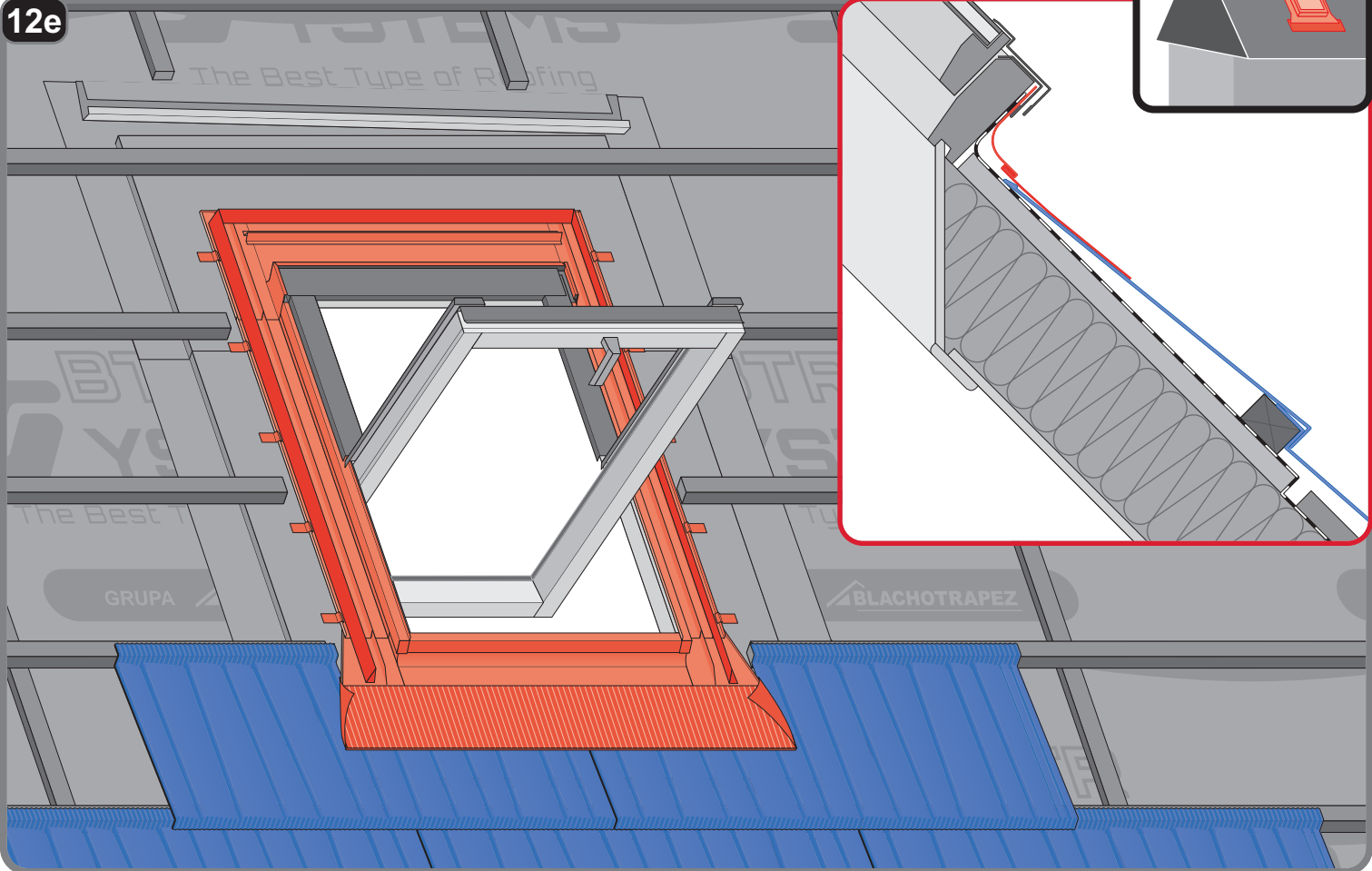

12f

